

## TPS9263x-Q1 Three-Channel Linear LED Driver With Analog and PWM Dimming

### 1 Features

- Qualified for Automotive Applications
- AEC-Q100 Qualified With the Following Results:
  - Device Temperature Grade 1:  $-40^{\circ}\text{C}$  to  $125^{\circ}\text{C}$  Ambient Operating Temperature Range
  - Device HBM ESD Classification Level H2
  - Device CDM ESD Classification Level C3B
- 3-Ch. LED Driver With Analog and PWM Dimming
- Wide Input-Voltage Range: 5 V–40 V
- Adjustable Constant Output Current Set by Reference Resistor
  - Max. Current: 150 mA per Channel
  - Max. Current: 450 mA in Parallel Operation Mode
  - Accuracy:  $\pm 1.5\%$  per Channel When  $I_{(IOUTx)} > 30\text{ mA}$
  - Accuracy:  $\pm 2.5\%$  per Device When  $I_{(IOUTx)} > 30\text{ mA}$
- Parallel Outputs for Higher Current Using Multiple ICs or Multiple Channels of a Single IC
- Low Dropout Voltage
  - Max. Dropout: 400 mV at 60 mA per Channel
  - Max. Dropout: 0.9 V at 150 mA per Channel
- Independent PWM Dimming per Channel
- Open and Shorted LED Detection With Deglitch Timer
- LED String Voltage Feedback per Channel for Single-LED Short Detection
- Separate Fault Terminal for Single-LED Short Failure
- Fault Terminal for Open, Short, and Thermal Shutdown Failure Reporting, Allowing Parallel Bus Connection up to 15 Devices

- IC Accommodates a Slow Input-Voltage  $dV/dt$  ( $0.5\text{ V/min}$ ) With No Issues
- Two Options for Device Temperature Information
  - TPS92630-Q1: Temperature-Current Foldback to Prevent Thermal Shutdown, With Programmable Threshold
  - TPS92631-Q1: Analog Voltage Output Proportional to the Device Temperature
- Operating Junction Temperature Range  $-40^{\circ}\text{C}$  to  $150^{\circ}\text{C}$
- Package: 16-Terminal Thermally Enhanced PWP Package (HTSSOP)

### 2 Applications

- Automotive LED Lighting Applications, Such As:
  - Daytime Running Light
  - Position Light
  - Fog Light
  - Rear Light
  - Stop or Taillight
  - Interior Lighting

### 3 Description

The TPS9263x-Q1 devices are three-channel linear LED drivers with analog and PWM dimming control. Their full-diagnostic and built-in protection capabilities make them the ideal solution for variable-intensity LED lighting applications up to the medium-power range.

#### Device Information

ORDER NUMBER	PACKAGE	BODY SIZE
TPS92630QPWRQ1	PDSO (16)	4,4 mm × 5 mm
TPS92631QPWRQ1	PDSO (16)	4,4 mm × 5 mm

#### Typical Application Schematic

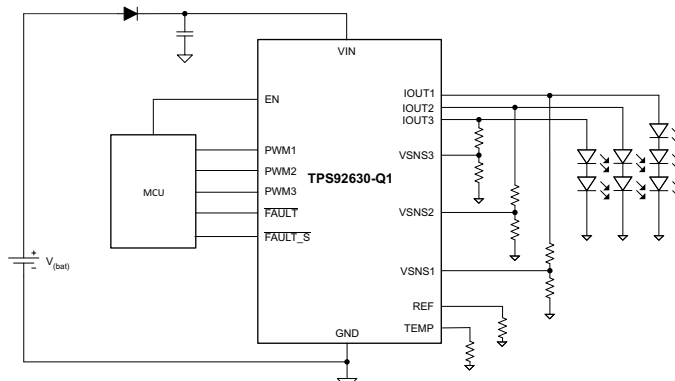

## Table of Contents

<b>1 Features</b> .....	<b>1</b>	9.2 Functional Block Diagram .....	<b>13</b>
<b>2 Applications</b> .....	<b>1</b>	9.3 Feature Description .....	<b>13</b>
<b>3 Description</b> .....	<b>1</b>	9.4 Device Functional Modes .....	<b>21</b>
<b>4 Revision History</b> .....	<b>2</b>	<b>10 Applications and Implementation</b> .....	<b>23</b>
<b>5 Description (Continued)</b> .....	<b>3</b>	10.1 Application Information .....	<b>23</b>
<b>6 Terminal Configuration and Functions</b> .....	<b>4</b>	10.2 Typical Applications .....	<b>23</b>
<b>7 Specifications</b> .....	<b>4</b>	<b>11 Power Supply Recommendations</b> .....	<b>30</b>
7.1 Absolute Maximum Ratings .....	<b>4</b>	<b>12 Layout</b> .....	<b>31</b>
7.2 Handling Ratings .....	<b>5</b>	12.1 Layout Guidelines .....	<b>31</b>
7.3 Recommended Operating Conditions .....	<b>5</b>	12.2 Layout Example .....	<b>31</b>
7.4 Thermal Information .....	<b>5</b>	<b>13 Device and Documentation Support</b> .....	<b>32</b>
7.5 Electrical Characteristics .....	<b>6</b>	13.1 Related Links .....	<b>32</b>
7.6 Timing Requirements .....	<b>8</b>	13.2 Trademarks .....	<b>32</b>
7.7 Typical Characteristics .....	<b>9</b>	13.3 Electrostatic Discharge Caution .....	<b>32</b>
<b>8 Parameter Measurement Information</b> .....	<b>12</b>	13.4 Glossary .....	<b>32</b>
<b>9 Detailed Description</b> .....	<b>13</b>	<b>14 Mechanical, Packaging, and Orderable Information</b> .....	<b>33</b>
9.1 Overview .....	<b>13</b>		

## 4 Revision History

Date	Version	Notes
February 2014	*	Initial release

## 5 Description (Continued)

The design of this device suits it well for driving LEDs configured as a single string or multiple strings within its power capability. A single device can drive up to three strings with one to three LEDs in each string at a total current of up to 150 mA per channel. Outputs can be paralleled to provide higher current drive capability to 450 mA.

In multiple-string applications, the device offers the advantage of having common-cathode connection of the LED strings. So, there is only a single return wire needed instead of one per LED string that a system with low-side current sense would need.

A single-LED short comparator allows detection of single LED failing with a short circuit. Fault output can support bus connection topology between multiple ICs.

The included temperature monitor reduces the LED drive current if the IC junction temperature exceeds a thermal threshold. One can program the temperature threshold through an external resistor. One can disable the thermal current-monitor feature by connecting the TEMP terminal to ground. Output of the junction temperature as an analog voltage is available as a factory program option.

## 6 Terminal Configuration and Functions

16-Terminal PDSO With PowerPAD™ Thermal Pad  
 PWP Package  
 (Top View)

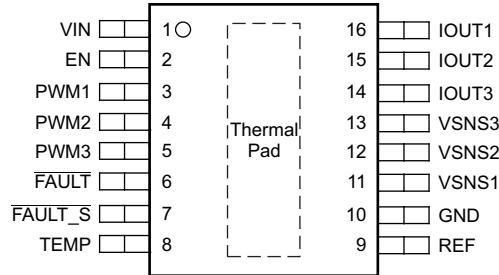

Terminal Functions

TERMINAL		I/O	DESCRIPTION	COMMENT
NAME	NO.			
EN	2	I	Enable and shut down	
$\overline{\text{FAULT}}$	6	I/O	Fault terminal	Floating when not used
$\overline{\text{FAULT\_S}}$	7	I/O	Single-LED short fault	Floating when not used
GND	10	–	Ground	
IOUT1	16	O	Current output terminal	Connect to VSNS3 when not used.
IOUT2	15	O	Current output terminal	Connect to VSNS2 when not used.
IOUT3	14	O	Current output terminal	Connect to VSNS1 when not used.
PWM1	3	I	PWM input and channel ON or OFF	Tie to GND when this channel is not used.
PWM2	4	I	PWM input and channel ON or OFF	Tie to GND when this channel is not used.
PWM3	5	I	PWM input and channel ON or OFF	Tie to GND when this channel is not used.
REF	9	O	Reference resistor terminal for normal current setting	
TEMP	8	I/O	Temperature foldback threshold program	Tie to GND when not used.
VIN	1	–	Input terminal – VBAT supply	
VSNS1	11	I	String voltage sense	Connect to IOUT1 when not used.
VSNS2	12	I	String voltage sense	Connect to IOUT2 when not used.
VSNS3	13	I	String voltage sense	Connect to IOUT3 when not used.

## 7 Specifications

### 7.1 Absolute Maximum Ratings<sup>(1)</sup>

		MIN	MAX	UNIT
VIN, IOUTx, PWMx, EN, VSNSx	Unregulated input <sup>(2)(3)(4)</sup>	–0.3	45	V
$\overline{\text{FAULT}}$ , $\overline{\text{FAULT\_S}}$	See <sup>(2)(3)</sup>	–0.3	22	V
Others	See <sup>(2)(3)</sup>	–0.3	7	V
T <sub>J</sub>	Virtual junction temperature range	–40	150	°C
T <sub>A</sub>	Operating ambient temperature range	–40	125	°C

- (1) Stresses beyond those listed under *Absolute Maximum Ratings* may cause permanent damage to the device. These are stress ratings only, and functional operation of the device at these or any other conditions beyond those indicated under *Recommended Operating Conditions* is not implied. Exposure to absolute-maximum-rated conditions for extended periods may affect device reliability.
- (2) All voltage values are with respect to GND.
- (3) Absolute negative voltage on these terminals not to go below –0.3 V
- (4) Absolute maximum voltage 45 V for 200 ms

## 7.2 Handling Ratings

		MIN	MAX	UNIT
$T_{stg}$	Storage temperature range	-65	150	°C
$V_{(ESD)}^{(1)}$	Human-body model (HBM) <sup>(2)</sup> AEC-Q100 Classification Level H2	-2	2	kV
	Charged-device model (CDM) (corner terminals) <sup>(3)</sup>	-750	750	V
	Charged-device model (CDM) (other terminals) <sup>(3)</sup>	-500	500	

- (1) Electrostatic discharge (ESD) to measure device sensitivity and immunity to damage caused by assembly-line electrostatic discharges into the device.
- (2) The human-body model is a 107-pF capacitor discharged through a 1.5-k $\Omega$  resistor into each terminal.
- (3) The charged-device model is tested according to AEC\_Q100-011C.

## 7.3 Recommended Operating Conditions

		MIN	MAX	UNIT
$V_{IN}$		5	40	V
PWMx, EN, VSNSx		0	40	V
FAULT, FAULT_S		0	20	V
Others		0	5	V
$T_J$	Operating junction temperature range	-40	150	°C

## 7.4 Thermal Information

THERMAL METRIC <sup>(1)</sup>		TPS92631-Q1 PWP (16 TERMINALS)	TPS92630-Q1 PWP (16 TERMINALS)	UNIT
$R_{\theta JA}$	Junction-to-ambient thermal resistance <sup>(2)</sup>	41.5	41.5	°C/W
$R_{\theta JC(top)}$	Junction-to-case (top) thermal resistance	29.6	29.6	°C/W
$R_{JB\theta}$	Junction-to-board thermal resistance	24	24	°C/W
$\psi_{JT}$	Junction-to-top characterization parameter	1	1	°C/W
$\psi_{JB}$	Junction-to-board characterization parameter	23.8	23.8	°C/W
$R_{\theta JC(bot)}$	Junction-to-case (bottom) thermal resistance	3.4	3.4	°C/W

- (1) For more information about traditional and new thermal metrics, see the IC Package Thermal Metrics application report, [SPRA953](#).
- (2) The thermal data is based on JEDEC standard high-K profile – JESD 51-7. The copper pad is soldered to the thermal land pattern. Also, correct attachment procedure must be incorporated.

## 7.5 Electrical Characteristics

$V_{(VIN)} = 14\text{ V}$ ,  $T_J = -40^\circ\text{C}$  to  $150^\circ\text{C}$  (unless otherwise stated)

PARAMETER		TEST CONDITIONS	MIN	TYP	MAX	UNIT
<b>SUPPLY VOLTAGE AND CURRENT (VIN)</b>						
$V_{(VIN)}$	Input voltage		5		40	V
$I_{(quiescent)}$	Quiescent current	All PWMx = high, $I_{(IOUTx)} = 100\text{ mA}$ , Not including $I_{ref}$	0.5	0.6	0.85	mA
$I_{(Shutdown)}$	Shutdown current	$V_{(EN)} = 0\text{ V}$			10	$\mu\text{A}$
$I_{(fault)}$	Shutdown current in fault mode (device to GND)	PWM = EN = high, FAULT = low, $V_{(VIN)} = 5\text{ V}$ – $40\text{ V}$ , $I = 100\text{ mA}$	0.5	0.6	0.85	mA
	Shutdown current in fault mode (from Vin)	PWM = EN = high, FAULT = low, $V_{(VIN)} = 5\text{ V}$ – $40\text{ V}$ , $I = 100\text{ mA}$			2	
<b>PWMx AND EN</b>						
$V_{IL(EN)}$	Logic input, low level	IOUTx disabled	0		0.7	V
$V_{IH(EN)}$	Logic input, high level	IOUTx enabled	2			V
$I_{(EN-pd)}$	EN internal pulldown	$V_{(EN)} = 0\text{ V}$ to $40\text{ V}$	0.35		2.5	$\mu\text{A}$
$V_{IL(PWMx)}$	Logic input, low level	IOUTx disabled	1.161	1.222	1.283	V
$V_{IH(PWMx)}$	Logic input, high level	IOUTx enabled	1.135	1.195	1.255	V
$V_{(PWM-hys)}$	Hysteresis			44		mV
$I_{(PWM-pd)}$	PWMx internal pulldown current	$V_{(PWMx)} = 40\text{ V}$	100	180	250	nA
<b>CURRENT REGULATION (IOUTx)</b>						
$I_{(IOUTx)}$	Regulated output current range	Each channel	10		150	mA
		Three channels in parallel mode	30		450	
$\Delta I_{O(channel)}$	Channel accuracy	$10\text{ mA} < I_{(IOUTx)} < 30\text{ mA}$ , $V_{(VIN)} = 5\text{ V}$ – $40\text{ V}$ Channel accuracy = $\frac{I_{(IOUTx)} - I_{(avg)}}{I_{(avg)}}$ (1)	-3%		3%	
		$30\text{ mA} \leq I_{(IOUTx)} < 150\text{ mA}$ , $V_{in} = 5\text{ V}$ – $40\text{ V}$ Channel accuracy = $\frac{I_{(IOUTx)} - I_{(avg)}}{I_{(avg)}}$ (1)	-1.5%		1.5%	
$\Delta I_{O(device)}$	Device accuracy	$10\text{ mA} < I_{OUT} < 30\text{ mA}$ , $V_{(VIN)} = 5\text{ V}$ to $20\text{ V}^{(2)}$ Device accuracy = $\frac{I_{(IOUTx)} - I_{(setting)}}{I_{(setting)}}$ (3)	-4%		4%	
		$30\text{ mA} \leq I_{OUT} < 150\text{ mA}$ , $V_{(VIN)} = 5\text{ V}$ to $20\text{ V}^{(2)}$ Device accuracy = $\frac{I_{(IOUTx)} - I_{(setting)}}{I_{(setting)}}$ (3)	-2.5%		2.5%	
$V_{ref}$	Reference voltage		1.198	1.222	1.246	V
$K_{(I)}$	Ratio of $I_{(IOUTx)}$ to reference current			100		
$V_{(DROP)}$	Dropout voltage	At 150 mA load per channel		0.7	1	V
		At 60 mA load per channel			0.4	V
$I_{(slew)}$	Current slew-rate rise and fall times	Current rising from 10% to 90% or falling from 90% to 10% at $I_{(IOUTx)} = 60\text{ mA}$ . <sup>(4)</sup>	4	8	15	mA/ $\mu\text{s}$
		Current rising from 10% to 90% or falling from 90% to 10% at $I_{(IOUTx)} = 150\text{ mA}$ . <sup>(4)</sup>	7	14	25	mA/ $\mu\text{s}$

(1)  $I_{(AVG)} = [I_{(IOUT1)} + I_{(IOUT2)} + I_{(IOUT3)}] / 3$

(2) For  $V_{(VIN)}$  voltages higher than 20 V, see [Figure 2](#) and [Figure 3](#).

(3)  $I_{(setting)}$  is the target current set by  $R_{REF}$ .

(4) See [Figure 17](#) for the load model for the slew-rate test and delay-time test.

## Electrical Characteristics (continued)

 $V_{(VIN)} = 14\text{ V}$ ,  $T_J = -40^\circ\text{C}$  to  $150^\circ\text{C}$  (unless otherwise stated)

PARAMETER		TEST CONDITIONS	MIN	TYP	MAX	UNIT
<b>FAULT (FAULT)</b>						
$V_{IL}$	Logic input low threshold				0.7	V
$V_{IH}$	Logic input high threshold		2			V
$V_{OL}$	Logic output low level	Tested with 500- $\mu\text{A}$ external pullup			0.7	V
$V_{OH}$	Logic output high level	Tested with 1- $\mu\text{A}$ external pulldown	2			V
$I_{(\text{pulldown})}$	Strong pulldown current		500	750	1000	$\mu\text{A}$
$I_{(\text{pullup})}$	Strong pullup current		4	8	16	$\mu\text{A}$
<b>COMPARATOR (VSNSx)</b>						
$V_{(VSNSx)}$	Internal comparator reference (for short circuit detection)	$V_{(VIN)} > V_{(\text{th})}$	1.198	1.222	1.246	V
$I_{\text{lk}}$	Leakage current	$V_{(VSNSx)} = 3\text{ V}$			500	nA
$V_{(\text{th})}$	Vin voltage at which the chip enables the single-short alarm function	Single-short detection enabled	8		9	V
	$V_{\text{th}}$ hysteresis			145		mV
<b>PROTECTION</b>						
$V_{(\text{OLV})}$	Open-load detection voltage	$V_{(\text{OLV})} = V_{(VIN)} - V_{(\text{IOUTx})}$	50	100	150	mV
$V_{(\text{OL-hys})}$	Open-load detection hysteresis		100	200	300	mV
$V_{(\text{SV})}$	Short-detection voltage		0.846	0.89	0.935	V
	Short-detection hysteresis		318	335	352	mV
	Short-detection deglitch	During PWM, count the number of continuous cycles when $V_{\text{OUT}} < V_{(\text{SV})}$	1	2	3	ms
			7		8	
$R_{(\text{REF\_open})}$	REF terminal resistor open detection	FAULT goes low	15	23	57	k $\Omega$
$R_{(\text{REF\_short})}$	REF terminal resistor short detection	FAULT goes low	350	470	800	$\Omega$
<b>THERMAL MONITOR</b>						
$T_{(\text{shutdown})}$	Thermal shutdown		155	170		$^\circ\text{C}$
$T_{(\text{Hyst})}$	Thermal shutdown hysteresis			15		$^\circ\text{C}$
$T_{(\text{th})}$	Thermal foldback activation temperature (TPS92630-Q1 only)	90% of $I_{\text{out}}$ normal (TEMP terminal floating)	95	110	125	$^\circ\text{C}$
$I_{(\text{TFC-min})}$	Minimum foldback current (TPS92630-Q1 only)		40%	50%	60%	
$V_{(\text{T-disable})}$	Thermal-foldback-function disable voltage (TPS92630-Q1 only)			0	0.2	V
$K_{(\text{temp1})}$	Change of $V_{\text{ref}}$ relative to $T_J$ (TPS92630-Q1 only)			25		mV/ $^\circ\text{C}$
$K_{(\text{temp2})}$	Change of $V_{(\text{TEMP})}$ relative to $T_J$ (TPS92631-Q1 only)			25		mV/ $^\circ\text{C}$
$V_{(\text{T-analog})}$	Temperature voltage output on TEMP terminal (TPS92631-Q1 only)	$T_J = 95^\circ\text{C}$		0.2		V
		$T_J = 165^\circ\text{C}$		2		

## 7.6 Timing Requirements

			MIN	TYP	MAX	UNIT
$t_{(startup)}$	Start-up time	$V_{(VIN)} > 5\text{ V}$ , $I_{out} = 50\%$ , $I_{setting} = 60\text{ mA}$ <sup>(1)</sup>			200	$\mu\text{s}$
$t_{d(on)}$	Delay time between PWM rising edge to 10% of $I_{(IOUTx)}$	Two LEDs in series, 10-k $\Omega$ resistor in parallel		14	30	$\mu\text{s}$
$t_{d(off)}$	Delay time between PWM falling edge to 90% of $I_{(IOUTx)}$	Two LEDs in series, 10-k $\Omega$ resistor in parallel		25	45	$\mu\text{s}$
	Single-short detection deglitch		1	2	3	ms
		During PWM, count the number of continuous cycles when $V_{(VSNSx)} < 1.24\text{ V}$	7		8	Cycles
	Open-load detection deglitch		1	2	3	ms
		During PWM, count the number of continuous cycles when $V_{(VIN)} - V_{(IOUTx)} < V_{(OLV)}$	7		8	Cycles
	Short-detection deglitch		1	2	3	ms
		During PWM, count the number of continuous cycles when $V_{(IOUTx)} < V_{(SV)}$	7		8	Cycles

(1) Start-up is considered complete when  $I_{(setting)}$  increases to 30 mA.



## 7.7 Typical Characteristics

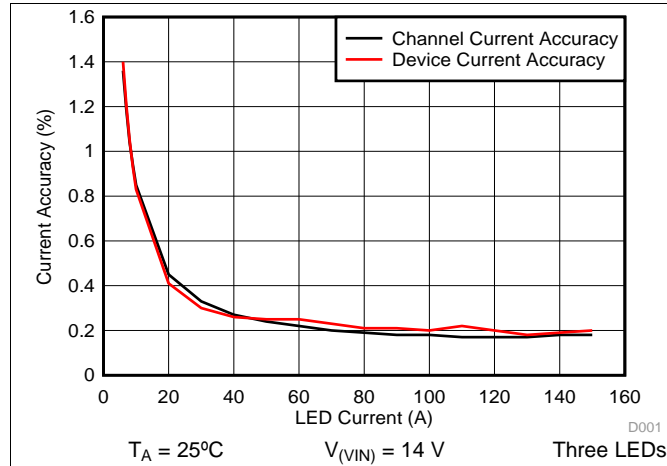

Figure 1. Current Accuracy versus Current Setting

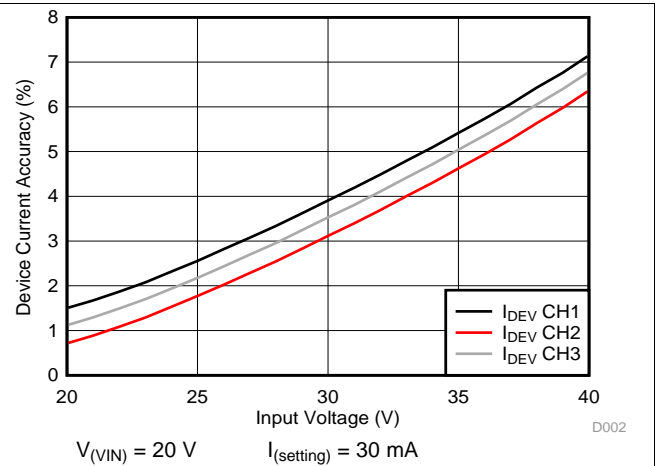

Figure 2. Device Current Accuracy versus Input Voltage

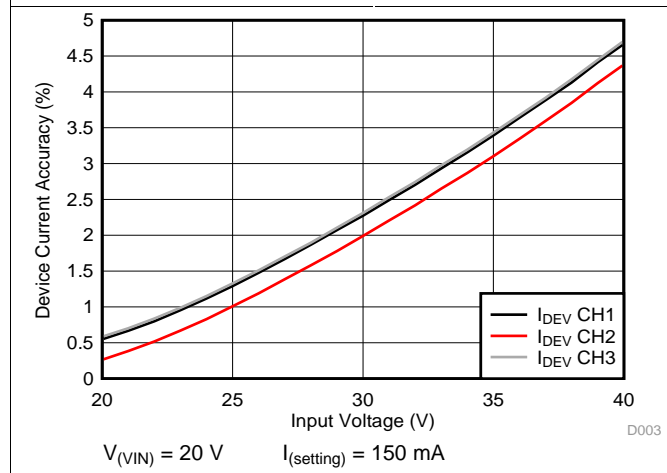

Figure 3. Device Current Accuracy versus Input Voltage

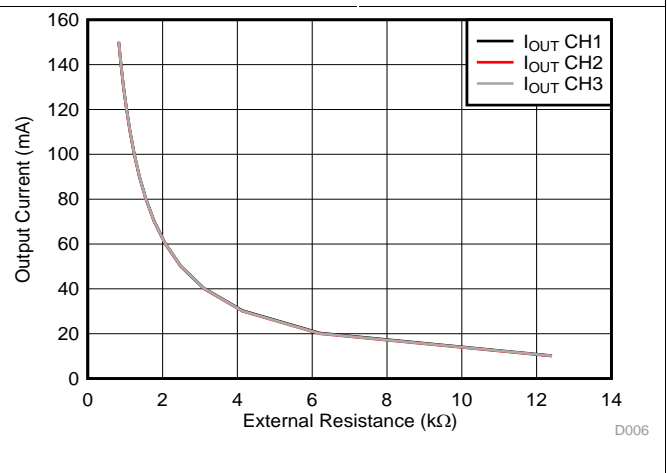

Figure 4. Output Current versus External Resistance

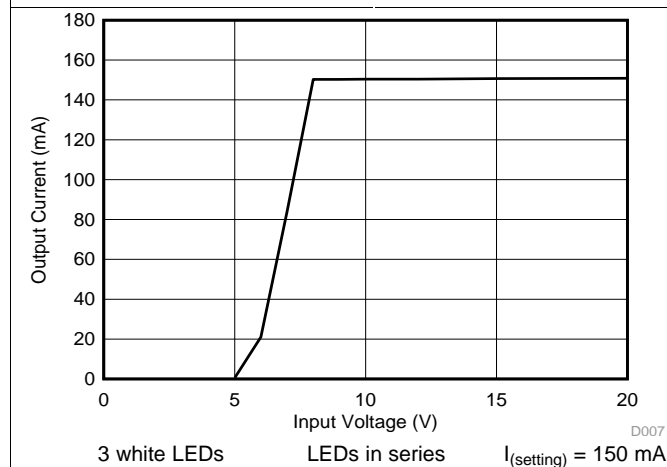

Figure 5. Output Current versus Input Voltage

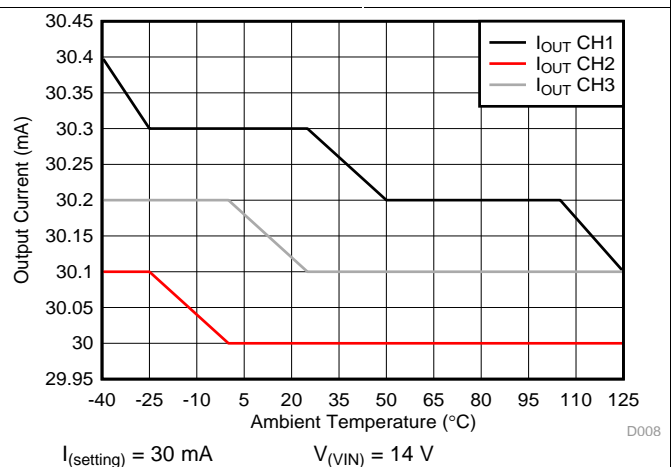
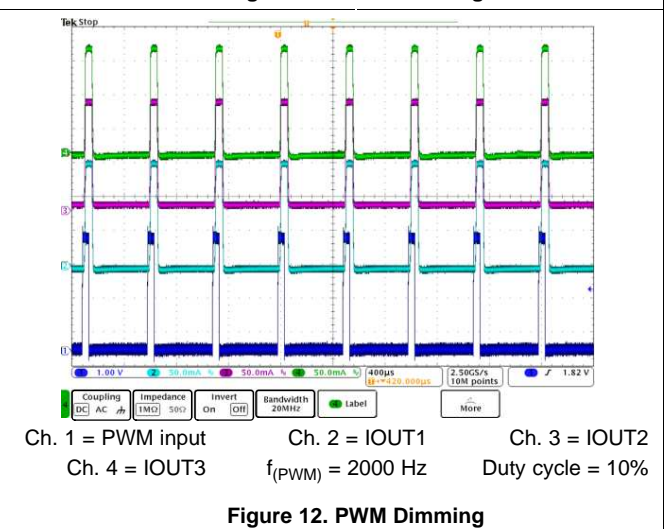
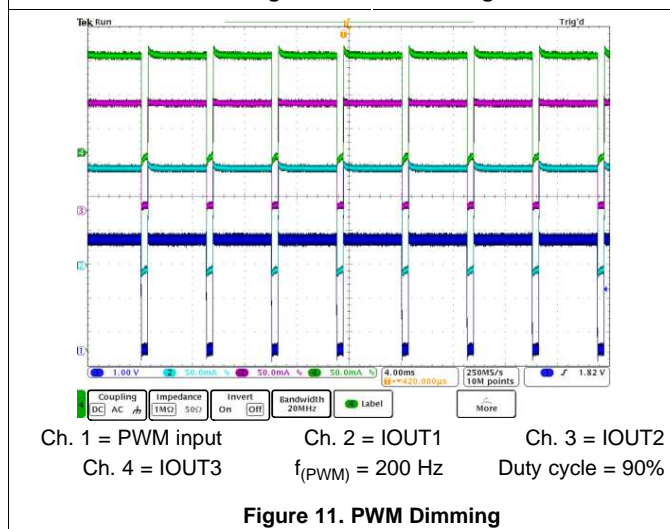
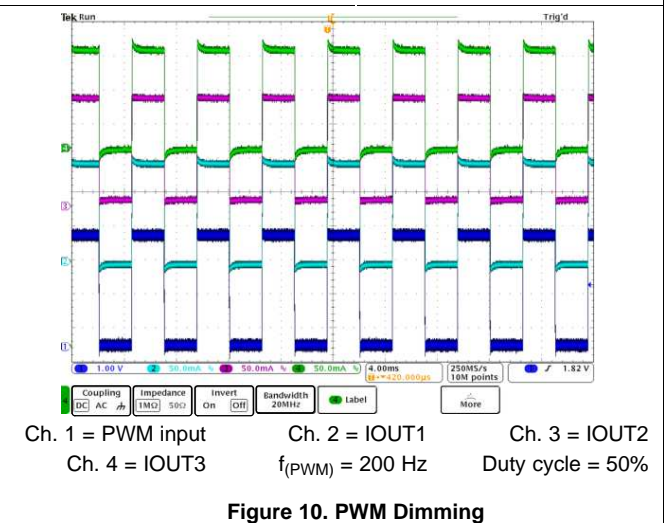
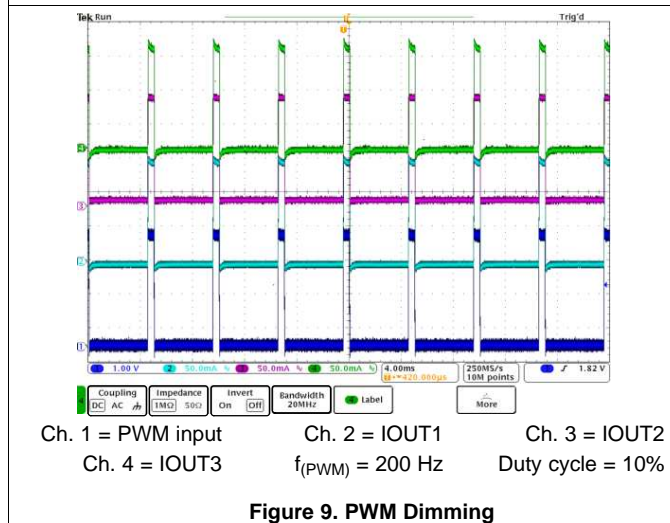
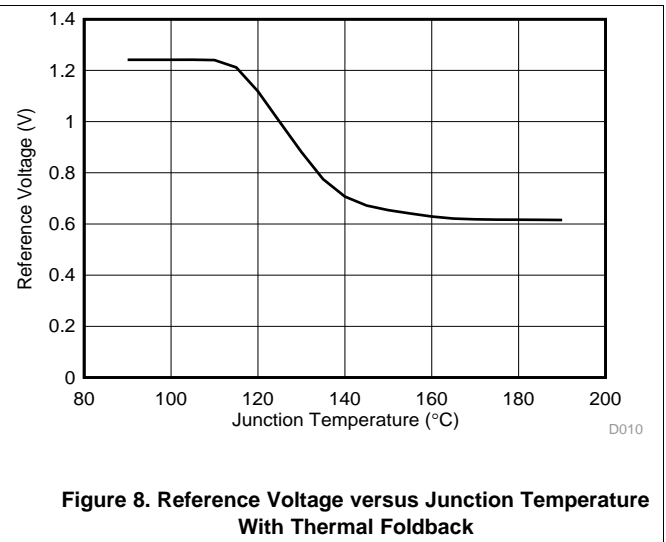
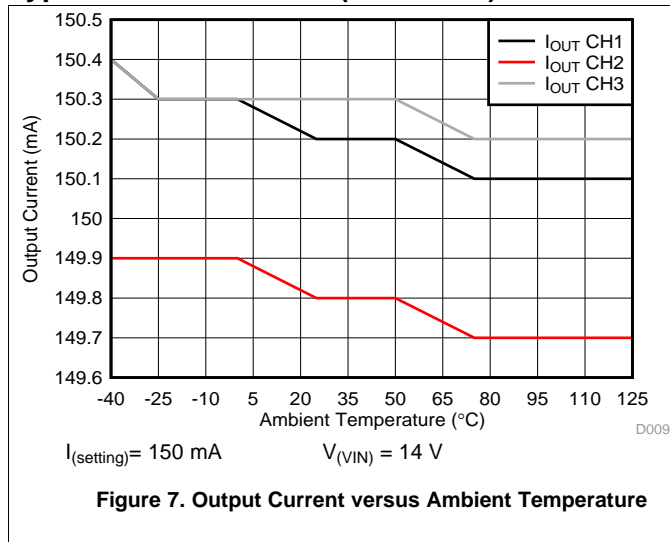

Figure 6. Output Current versus Ambient Temperature

**Typical Characteristics (continued)**



Typical Characteristics (continued)

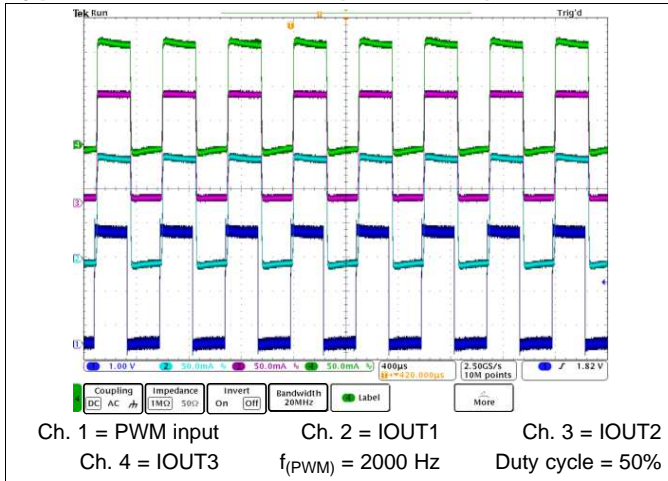

Figure 13. PWM Dimming

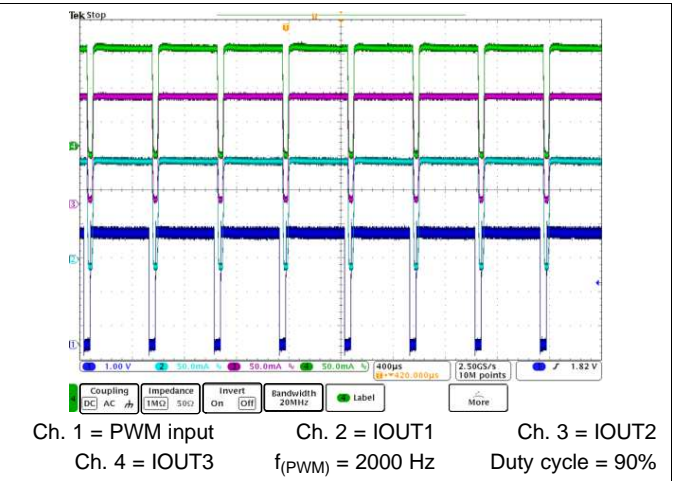

Figure 14. PWM Dimming

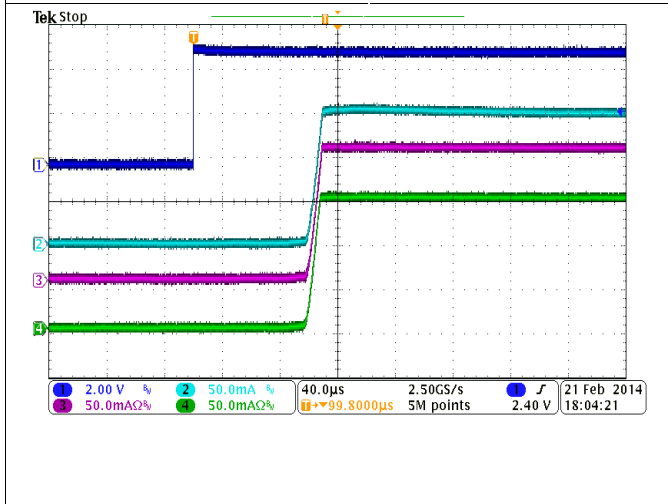

Figure 15. Fast Power-Up Waveform

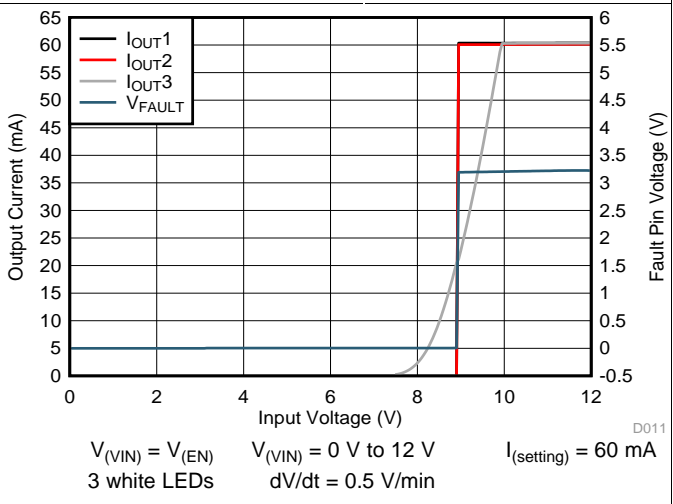
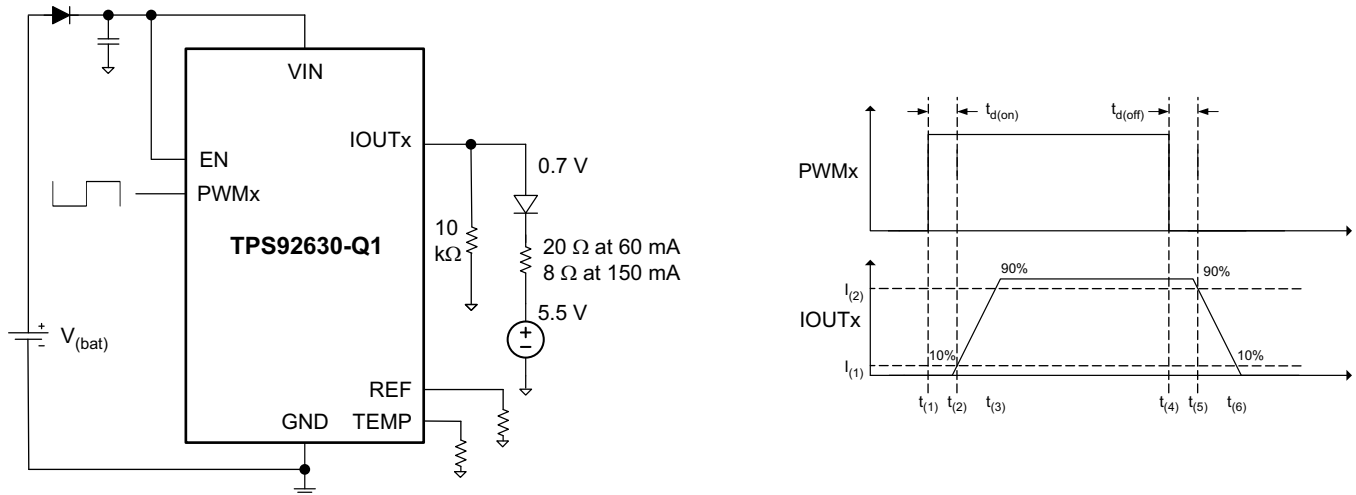

Figure 16. Slow Power-Up Waveform

## 8 Parameter Measurement Information



**Figure 17. Load Model for Slew-Rate and Delay-Time Tests**

## 9 Detailed Description

### 9.1 Overview

The TPS92630-Q1 device is a three-channel constant-current regulator with individual PWM dimming, designed for high brightness red or white LEDs in automotive lighting applications. Each channel has up to 150-mA current capability, giving a combined 450-mA current capability when paralleled. The device provides excellent current matching between channels and devices. A high-side current source allows LED common-cathode connections. The advanced control loop allows high accuracy between channels, even when different numbers of LEDs are connected on the output. Use of a separate PWM channel dims or disables each channel.

The TPS92630-Q1 device monitors fault conditions on the output and reports its status on the  $\overline{\text{FAULT}}$  and  $\overline{\text{FAULT\_S}}$  terminals. It features single-short-LED detection, output short-to-ground detection, open-load detection, and thermal shutdown. Two separate fault terminals allow maximum flexibility of fault-mode reporting to the MCU in case of an error. In case there is no MCU, one can connect multiple TPS92630-Q1 devices in a bus mode.

Integrated thermal foldback protects the devices from thermal shutdown by reducing the output current linearly when reaching a preset threshold. Use an external resistor to program the temperature foldback threshold. Tying the TEMP terminal to ground disables this function.

### 9.2 Functional Block Diagram

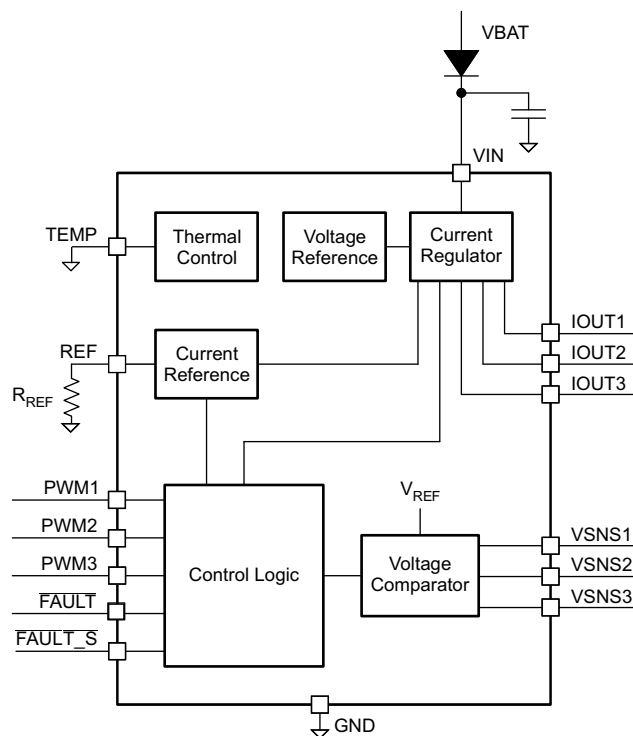

### 9.3 Feature Description

#### 9.3.1 Constant LED Current Setting

Control of the three LED output channels is through separate linear current regulators. A common external resistor sets the current in each channel. The device also features two current levels with external circuitry, intended for stop- and tail-light applications.

See [Equation 1](#) on how to set the current:

## Feature Description (continued)

$$I_{(IOUTx)} = \frac{V_{ref} \times K_{(I)}}{R_{(REF)}}$$

$$R_{(REF)} = \frac{V_{ref} \times K_{(I)}}{I_{(IOUTx)}} \quad (1)$$

### 9.3.2 PWM Control

The device features a separate PWM dimming control terminal for each output channel. PWM inputs also function as shutdown terminal when an output is unused. Tying PWM to ground disables the corresponding output. The PWM signal has a precise threshold, which one can use to define the start-up voltage of LED as an undervoltage-lockout (UVLO) function with the divider resistor from Vin.

### 9.3.3 FAULT Diagnostics

The TPS92630-Q1 device has two fault terminals, FAULT and FAULT\_S. FAULT\_S is a dedicated fault terminal for single-LED short failure and FAULT is for general faults, that is, short, open, and thermal shutdown. This allows the maximum flexibility based on all requirements and application conditions.

The device fault terminals can be connected to an MCU for fault reporting. Both fault terminals are open-drain transistors with a weak internal pullup. See [Figure 18](#).

Feature Description (continued)

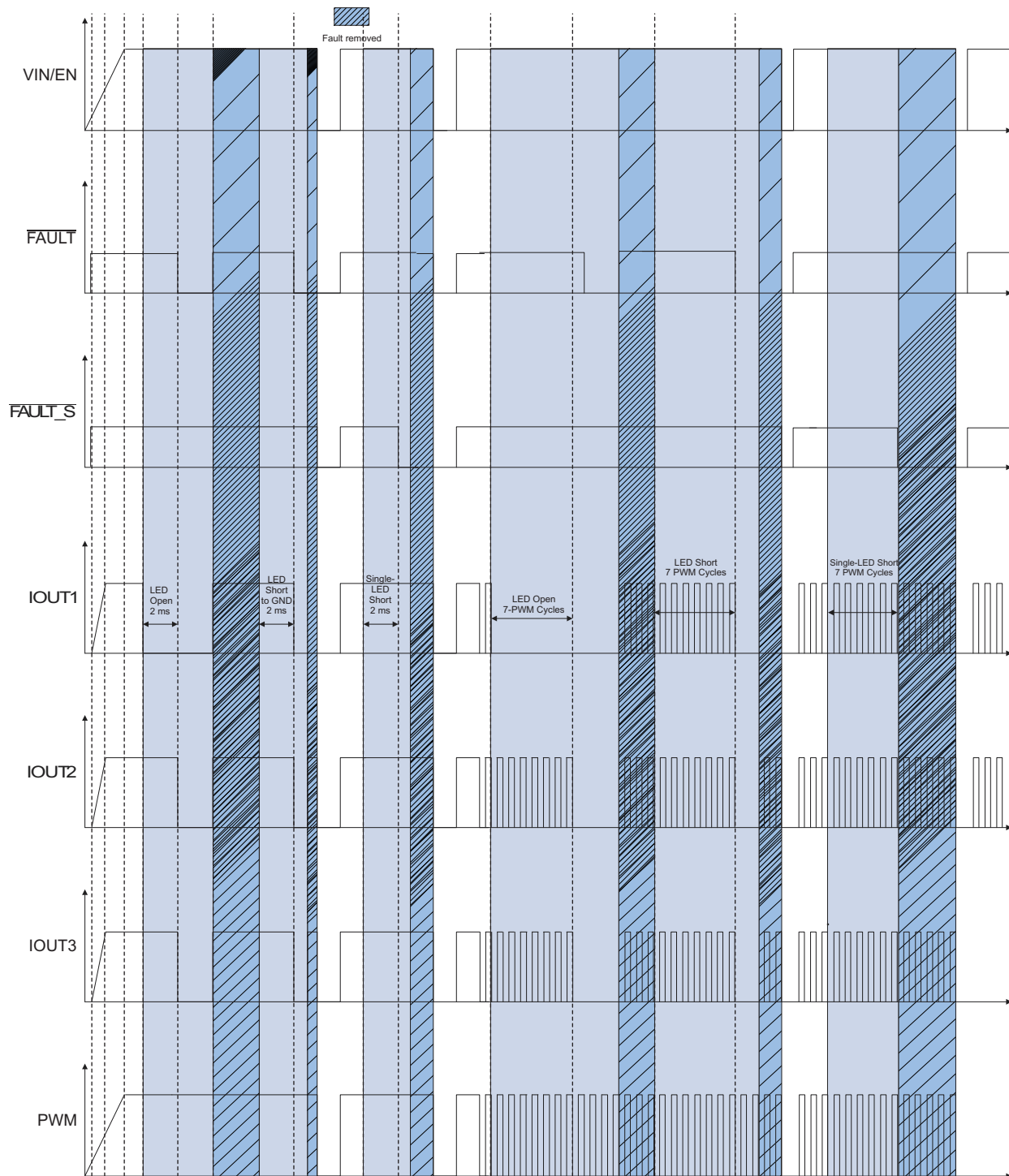
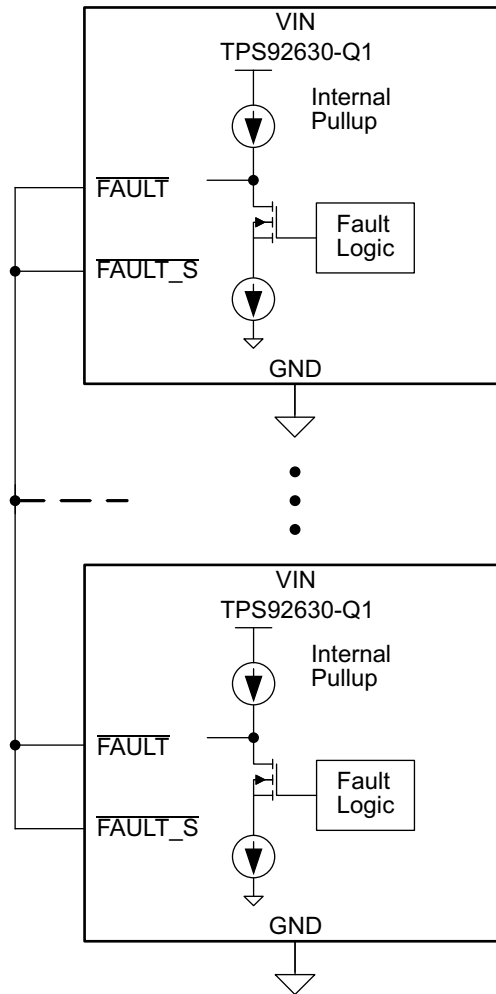

Figure 18. Detailed Timing Diagram

In case there is no MCU, one can connect up to 15 TPS92630-Q1  $\overline{\text{FAULT}}$  and  $\overline{\text{FAULT\_S}}$  terminals together. When one or more devices have errors, their respective  $\overline{\text{FAULT}}$  terminals go low, pulling the connected  $\overline{\text{FAULT}}$  bus down and shutting down all device outputs. [Figure 19](#) shows the fault-line bus connection.

**Feature Description (continued)**



**Figure 19. Fault-Line Bus Connection**

The device releases the FAULT bus when external circuitry pulls the  $\overline{\text{FAULT}}$  terminal high, on toggling of the EN terminal, or on a power cycle of the device. In case there is no MCU, only a power cycle clears the fault. See [Figure 20](#).



Feature Description (continued)

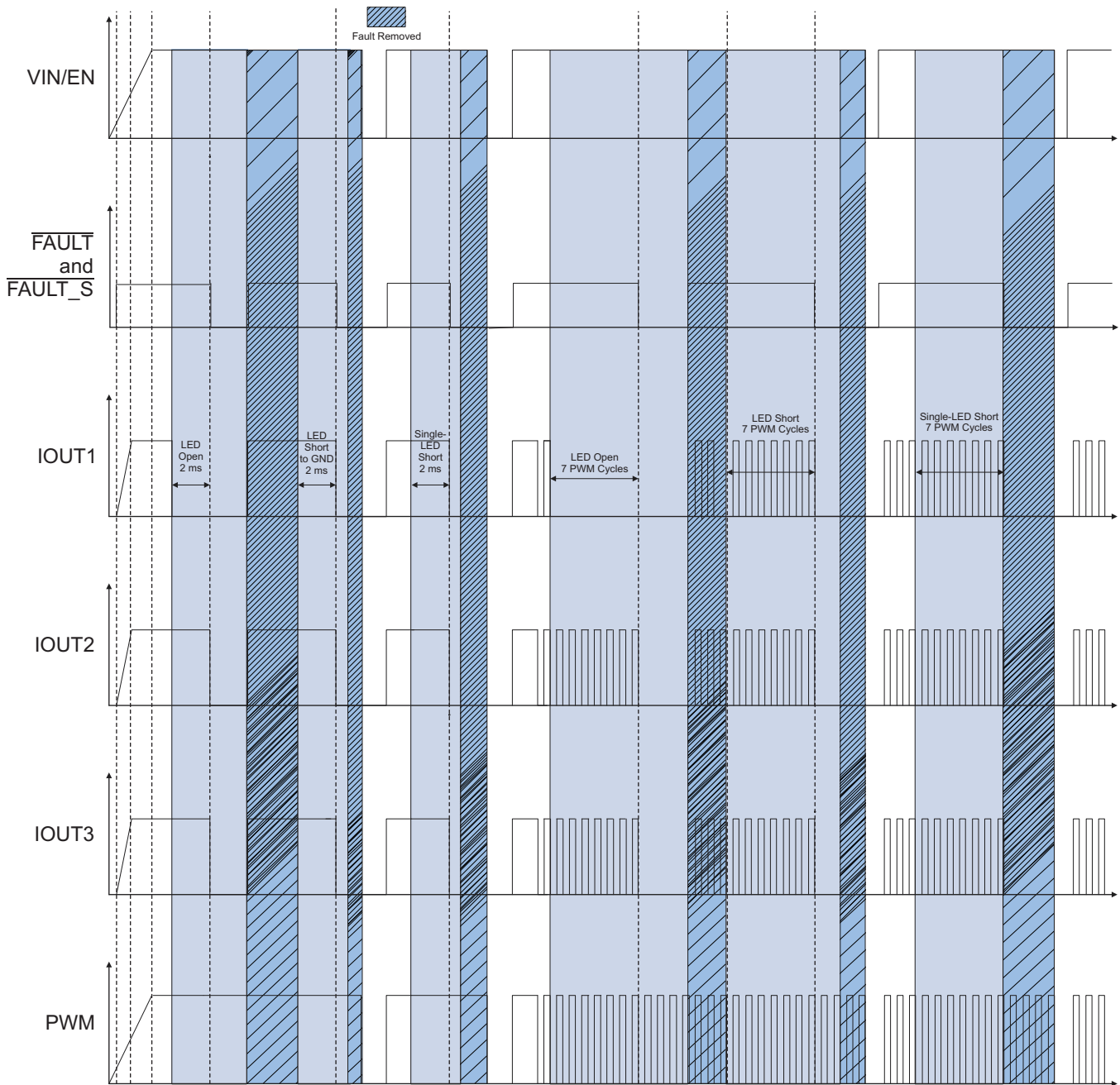

Figure 20. Detailed Timing Diagram

The following fault results in the  $\overline{\text{FAULT}}$  or  $\overline{\text{FAULT\_S}}$  terminal going low: thermal shutdown, open load, output short circuit, single LED short, and REF open or shorted. For thermal shutdown or LED open, release of the  $\overline{\text{FAULT}}$  terminal occurs when the thermal-shutdown or LED-open condition no longer exists. For other faults, the  $\overline{\text{FAULT}}$  and  $\overline{\text{FAULT\_S}}$  terminals stay low even if the condition does not exist; clearing the faults requires a power cycle of the device.

## Feature Description (continued)

### 9.3.4 Short-Circuit Detection

The device includes three internal comparators for LED forward-voltage measurement. With external resistor dividers, the device compares total LED forward voltage with the internal reference voltage. This feature enables the detection of one or more shorted LEDs. Any LED cathode or IOUTx terminal shorted to ground results in a short-circuit condition. The external resistor dividers control the detection-threshold-voltage setting.

Figure 21 illustrates different short-circuit conditions.

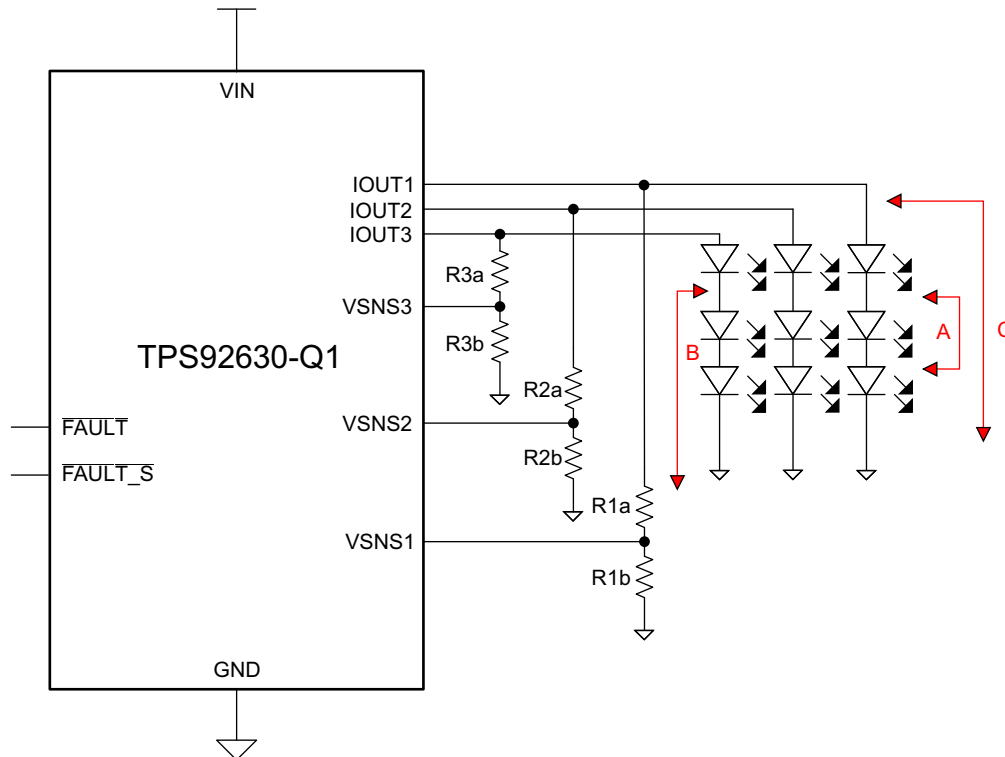

**Figure 21. Short-Circuit Conditions**

A short in one or more LEDs in a string (A and B as illustrated) registers as just a single-LED short when  $V_{(VIN)} > 9\text{ V}$ .

1. The device reports the failure to the MCU. The faulted channel continues sourcing current until the MCU takes actions to turn off channels through the EN or PWMx terminal.
2. No MCU: with  $\overline{\text{FAULT\_S}}$  floating, no action results. With  $\overline{\text{FAULT\_S}}$  tied to  $\overline{\text{FAULT}}$ , all output channels shut down together.

When an entire string of LED is shorted (C as illustrated), the device pulls  $\overline{\text{FAULT}}$  low to shut down all channels. With the  $\overline{\text{FAULT}}$  terminal tied high, only the faulted channel turns off.

- $V_{F(max)}$  – maximum forward voltage of LED used
- $V_{F(min)}$  – minimum forward voltage of LED used
- N – Number of LEDs used in a string
- R – resistor divider ratio
- $V_{(VSNSx)}$  – internal reference voltage of comparators

When selecting R, observe the following relationship to avoid false triggering.

$$R = (R_{xa} + R_{xb}) / R_{xb}$$

$$(N - 1) \times V_{F(max)} < V_{(VSNSx)} \times R < N \times V_{F(min)}$$

Feature Description (continued)

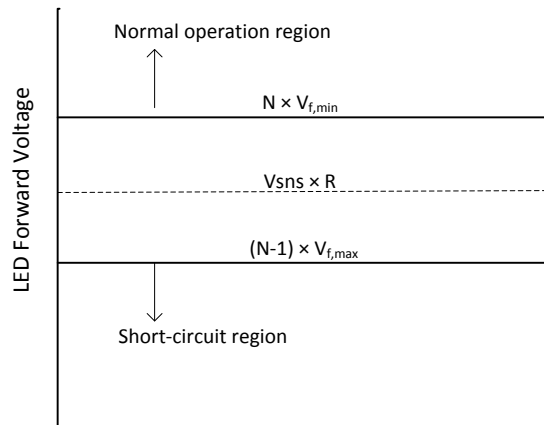

Figure 22. Single-LED Short-Trigger Calculation

9.3.5 Open-Load Detection

Detection of an open-load condition occurs when the voltage across the channel,  $V_{(VIN)} - V_{(IOUTx)}$ , is less than the open-load detection voltage,  $V_{OLV}$ . When this condition is present for more than the open-load-detection deglitch (2 ms when PWM is 100% on or one PWM on-time is more than 2 ms, or 7 continuous PMW duty cycles when in PWM dimming mode), the  $\overline{FAULT}$  terminal goes low, keeping the open channel on and turning the other channel off. With the  $\overline{FAULT}$  terminal tied high, all channels remain turned on. The channel recovers on removal of the open condition. Note that the device can detect an open load if the sum of the forward voltages of the LEDs in a string is close to or greater than the supply voltage on VIN.

Table 1. Fault Table<sup>(1)(2)</sup>

Failure Mode	Judgement Condition			Diagnostic Output Terminals	Action	$\overline{FAULT}$ and $\overline{FAULT\_S}$ <sup>(3)</sup>	Device Reaction	Failure Removed	Self-Clearing
	Detection VIN Voltage	Channel Status	Detection Mechanism						
<b>Short circuit:</b> 1 or several LED strings	$V_{(VIN)} > 5\text{ V}$	On	$V_{(IOUTx)} < 0.9\text{ V}$	$\overline{FAULT}$	Pulled low	Externally pulled high	Failing strings turned off, other channels on	Toggle EN, power cycle	No
						Floating	All strings turned OFF	Toggle EN, power cycle	
<b>Single-LED short circuit:</b> 1 or several LED strings	$V_{(VIN)} > 9\text{ V}$	On	$V_{(VSNSx)} < 1.222\text{ V}$	$\overline{FAULT\_S}$	Pulled low	Externally pulled high	All strings stay ON	Toggle EN, power cycle	No
						Floating	All strings stay ON	Toggle EN, power cycle	
<b>Open load:</b> 1 or several LED strings	$V_{(VIN)} > 5\text{ V}$	On	$V_{(VIN)} - V_{(IOUTx)} < 100\text{ mV}$	$\overline{FAULT}$	Pulled low	Externally pulled high	All strings stay ON		Yes
						Floating	Failing string stays ON, other channels turned OFF		
<b>Short to battery:</b> 1 or several LED strings	$V_{(VIN)} > 5\text{ V}$	On or off	$V_{(VIN)} - V_{(IOUTx)} < 100\text{ mV}$	$\overline{FAULT}$	Pulled low	Externally pulled high	All strings stay ON		Yes
						Floating	Failing string stays ON, other channels turned OFF		
<b>Thermal shutdown</b>	$V_{(VIN)} > 5\text{ V}$	On or off	Temperature $> 170^\circ\text{C}$	$\overline{FAULT}$	Pulled low	Externally pulled high	All strings turned OFF	Temperature $< 155^\circ\text{C}$	Yes
						Leave open			
<b>Thermal foldback</b>	$V_{(VIN)} > 5\text{ V}$	On or off	Temperature $> 110^\circ\text{C}$	N/A	None	N/A	All strings with reduced current	Temperature $< 100^\circ\text{C}$	Yes
<b>Reference resistor open or shorted</b>	$V_{(VIN)} > 5\text{ V}$	On or off	$R_{REF} > 57\text{ k}\Omega$ or $R_{REF} < 350\ \Omega$	$\overline{FAULT}$	Pulled low	N/A	All strings turned OFF	Toggle EN, power cycle	No

- (1) With diagnostic terminals  $\overline{FAULT}$  and  $\overline{FAULT\_S}$  tied high externally, pullup must be strong enough to override internal pulldown.
- (2) To achieve single-LED short circuit to turn off all strings,  $\overline{FAULT\_S}$  and  $\overline{FAULT}$  terminals must be connected together.
- (3) Pulling  $\overline{FAULT}$  and  $\overline{FAULT\_S}$  high externally changes the behavior of the device reaction. If not externally forced high, the device pulls the terminals low based on the failure mode.

### 9.3.6 Thermal Foldback

The TPS92630-Q1 device integrates thermal shutdown protection to prevent the IC from overheating. In addition, to prevent LEDs from flickering due to rapid thermal changes, the device includes a programmable thermal current foldback feature to reduce power dissipation at high junction temperatures.

The TPS92630-Q1 device reduces the LED current as the silicon junction temperature of the TPS92630-Q1 device increases (see Figure 23). By mounting the TPS92630-Q1 device on the same thermal substrate as the LEDs, use of this feature can also limit the dissipation of the LEDs. As the junction temperature of the TPS92630-Q1 device increases, the device reduces the regulated current, reducing the dissipated power in the TPS92630-Q1 device and in the LEDs. The current reduction is from the 100% level at typically 2% of  $I_{(setting)}$  per °C until the point at which the current drops to 50% of the full value.

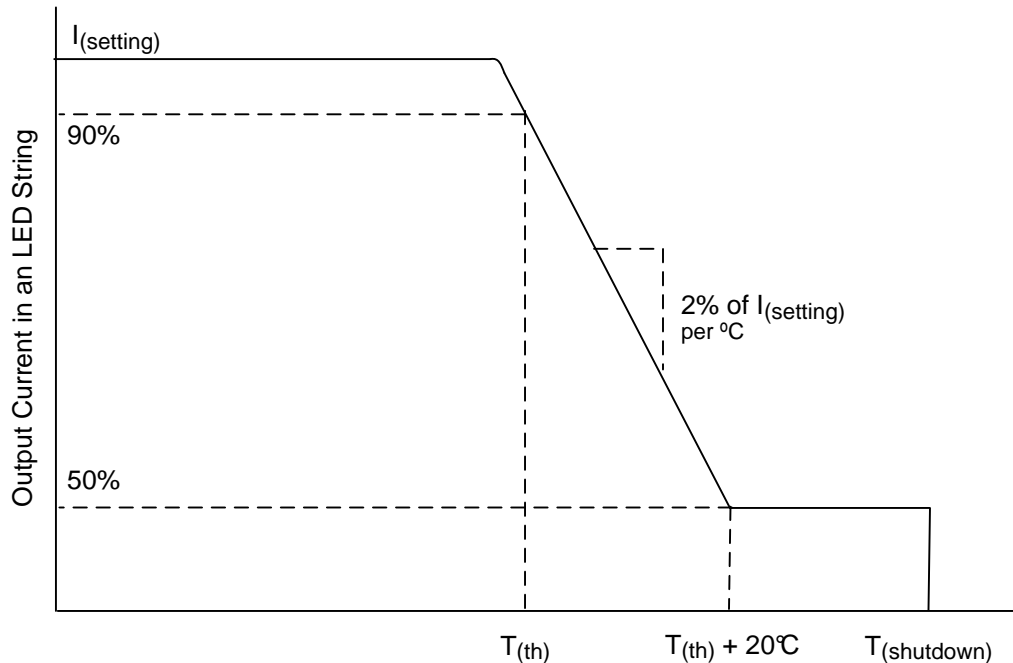

**Figure 23. Thermal Foldback**

Above this temperature, the current continues to reduce at a lower rate until the temperature reaches the overtemperature shutdown threshold temperature,  $T_{(shutdown)}$ . Changing the voltage on the TEMP terminal adjusts the temperature at which the current reduction begins. With TEMP floating, the definition of thermal monitor activation temperature,  $T_{(th)}$ , is the temperature at which the current reduction begins. The specification of  $T_{(th)}$  in the characteristics table is at the 90% current level.  $T_{(th)}$  increases as the voltage at the TEMP terminal,  $V_{(TEMP)}$ , declines and is defined as approximately:

$$T_{(th)} = -121.7 V_{(TEMP)} + 228.32$$

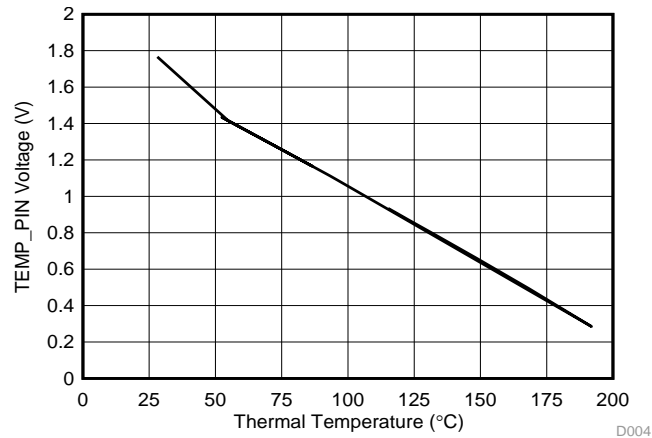

A resistor connected between TEMP and GND reduces  $V_{(TEMP)}$  and increases  $T_{(th)}$ . A resistor connected between TEMP and a reference supply greater than 1 V increases  $V_{(TEMP)}$  and reduces  $T_{(th)}$ .

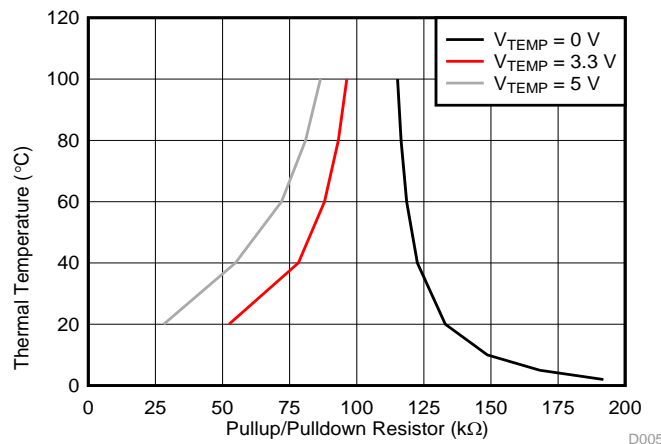

Figure 24. Pullup and Pulldown Resistors versus  $T_{(th)}$

Figure 24 shows how the nominal value of the thermal monitor activation temperature varies with the voltage at TEMP and with either a pulldown resistor to GND or with a pullup resistor to 3 V and to 5 V.

In extreme cases, if the chip temperature exceeds the overtemperature limit,  $T_{(SD)}$ , the device disables all channels. Temperature monitoring continues, and channel re-activation occurs when the temperature drops below the threshold provided by the specified hysteresis.

Note that it is possible for the TPS92630-Q1 device to transition rapidly between thermal shutdown and normal operation. This can happen if the thermal mass attached to the exposed thermal pad is small and  $T_{(th)}$  is increased to close to the shutdown temperature. The period of oscillation depends on  $T_{(th)}$ , the dissipated power, the thermal mass of any heatsink present, and the ambient temperature.

## 9.4 Device Functional Modes

### 9.4.1 Thermal Information

This device operates a thermal shutdown (TSD) circuit as a protection from overheating. For continuous normal operation, the junction temperature should not exceed the thermal-shutdown trip point. If the junction temperature exceeds the thermal-shutdown trip point, the output turns off. When the junction temperature falls below the thermal-shutdown trip point, the output turns on again.

Calculate the power dissipated by the device according to the following formula:

$$P_T = V_{(VIN)} \times I_{(VIN)} - n_1 \times V_{(LED1)} \times I_{(LED1)} - n_2 \times V_{(LED2)} \times I_{(LED2)} - n_3 \times V_{(LED3)} \times I_{(LED3)} - V_{ref}^2 / R_{(REF)}$$

where:

## Device Functional Modes (continued)

$P_T$  = Total power dissipation of the device

$n_x$  = Number of LEDs for channel x

$V_{(LEDx)}$  = Voltage drop across one LED for channel x

$V_{ref}$  = Reference voltage, typically 1.222 V

$I_{(LEDx)}$  = Average LED current for channel x

After determining the power dissipated by the device, calculate the junction temperature from the ambient temperature and the device thermal impedance.

$$T_J = T_A + R_{\theta JA} \times P_T$$

### 9.4.2 Operation With $V_{(VIN)} < 5$ V (Minimum $V_{(VIN)}$ )

The devices operate with input voltages above 5 V. The devices start working when  $V_{(VIN)} > 4$  V, but while  $4$  V  $< V_{(VIN)} < 5$  V, the devices shield all the fault status. This means that if any fault occurs, the devices may not report the fault and take the correct action.

### 9.4.3 Operation With $5$ V $< V_{(VIN)} < 9$ V (Lower-Than-Normal Automotive Battery Voltage)

The devices operate with input voltages above 5 V. When the input voltage is lower than normal automotive 9 V, the devices shield single-LED-short fault status. This means that if a single-LED-short fault occurs, the devices do not report the fault with the `FAULT_S` terminal.

## 10 Applications and Implementation

### 10.1 Application Information

The following discussion includes several applications showing how to implement the TPS92630-Q1 device for automotive lighting such as stop lights and taillights. Some of the examples demonstrate implementation of the fault bus function or detail use of the device for higher-current applications.

### 10.2 Typical Applications

#### 10.2.1 Simple Stop-Light and Taillight Application

For many automobiles, the same set of LEDs illuminates both taillights and stop lights. Thus, the LEDs must operate at two different brightness levels. Figure 25 shows two-level brightness adjustment using the TPS92630-Q1 device with minimum external components. Set the dimming level with a parallel resistor in REF through an external MOS. See Equation 2 for details.

$$I_{(IOUTx)} = \frac{V_{ref} \times K_{(I)}}{R_{(REF)} \times R_{(Stop)} / (R_{(REF)} + R_{(Stop)})} \quad (2)$$

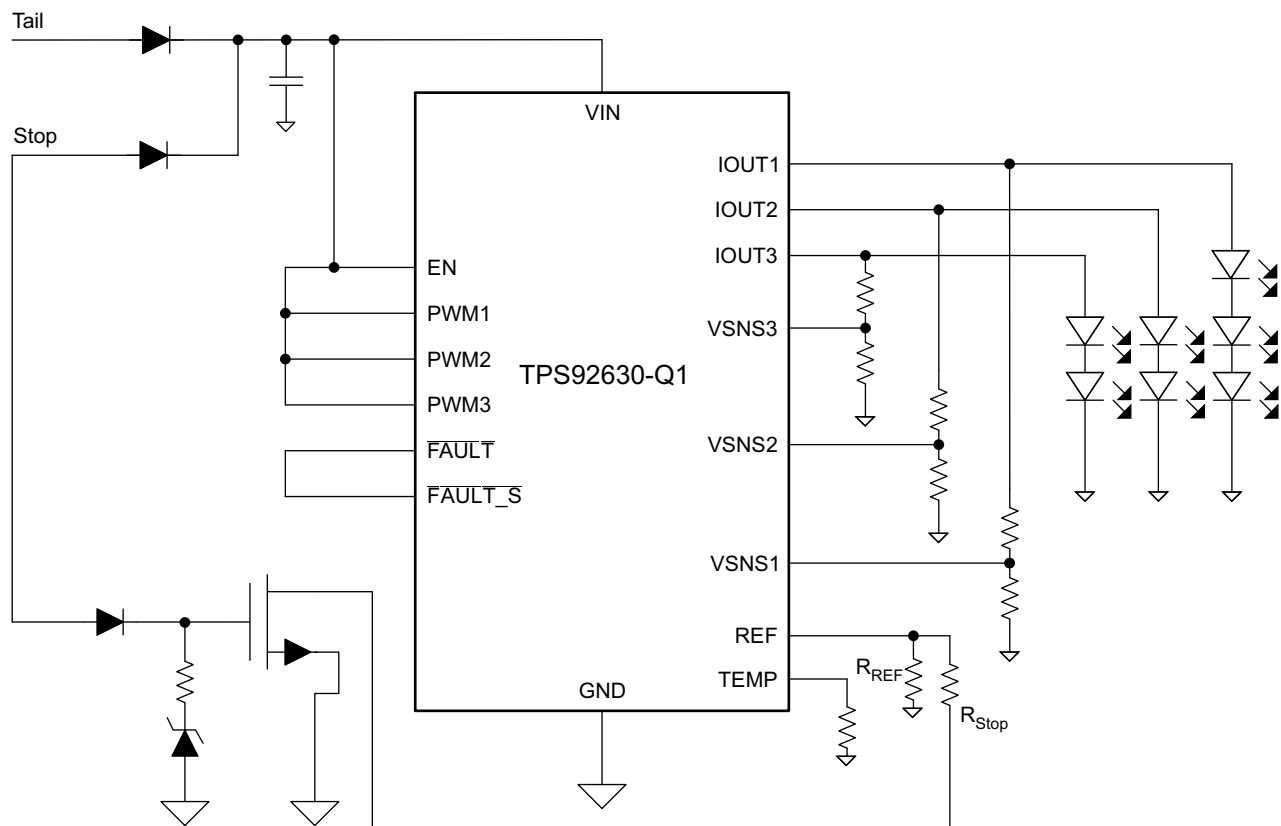

Figure 25. Two-Level Brightness Adjustment Using the TPS92630-Q1 Device With Minimum External Components

#### 10.2.1.1 Design Requirements

For this design example, use the following as the input parameters.

Table 2. Design Parameters

DESIGN PARAMETER	EXAMPLE VALUE
$I_{(tail)}$	30 mA
$I_{(stop)}$	70 mA

### 10.2.1.2 Detailed Design Procedure

#### 10.2.1.2.1 Step-by-Step Design Procedure

To begin the design process, one must decide on a few parameters. The designer must know the following:

- $I_{(tail)}$  – Taillight current
- $I_{(stop)}$  – Stop-light current

##### 10.2.1.2.1.1 $R_{(REF)}$

$$R_{(REF)} = V_{ref} \times K_{(I)} / I_{(tail)} = 1.222 \times 100 / 0.03 = 4.072 \text{ k}\Omega$$

##### 10.2.1.2.1.2 $R_{(Stop)}$

$$R_{(Stop)} = V_{ref} \times K_{(I)} / (I_{(stop)} - I_{(tail)}) = 1.222 \times 100 / (0.07 - 0.03) = 3.055 \text{ k}\Omega$$

### 10.2.2 Stoplight and Taillight Application With PWM Generator

Another easy way to achieve the different brightness is dimming by pulse-width modulation (PWM), which holds the color spectrum of the LED over its whole brightness range. The maximum current that passes through the LED is programmable by sense resistor  $R_{REF}$ .

Figure 26 shows the application circuit of the stoplight and taillight including an automotive-qualified timer, TLC555-Q1, the duty cycle of which is programmable by two external resistors. One can see that driving the STOP signal high pulls the PWM terminal constantly high, creating 100% duty cycle. Thus the LEDs operate at full brightness. When the TAIL signal is high, the LEDs operate at 50% brightness because the TLC555-Q1 timer is programmed at a fixed duty cycle of 50%.

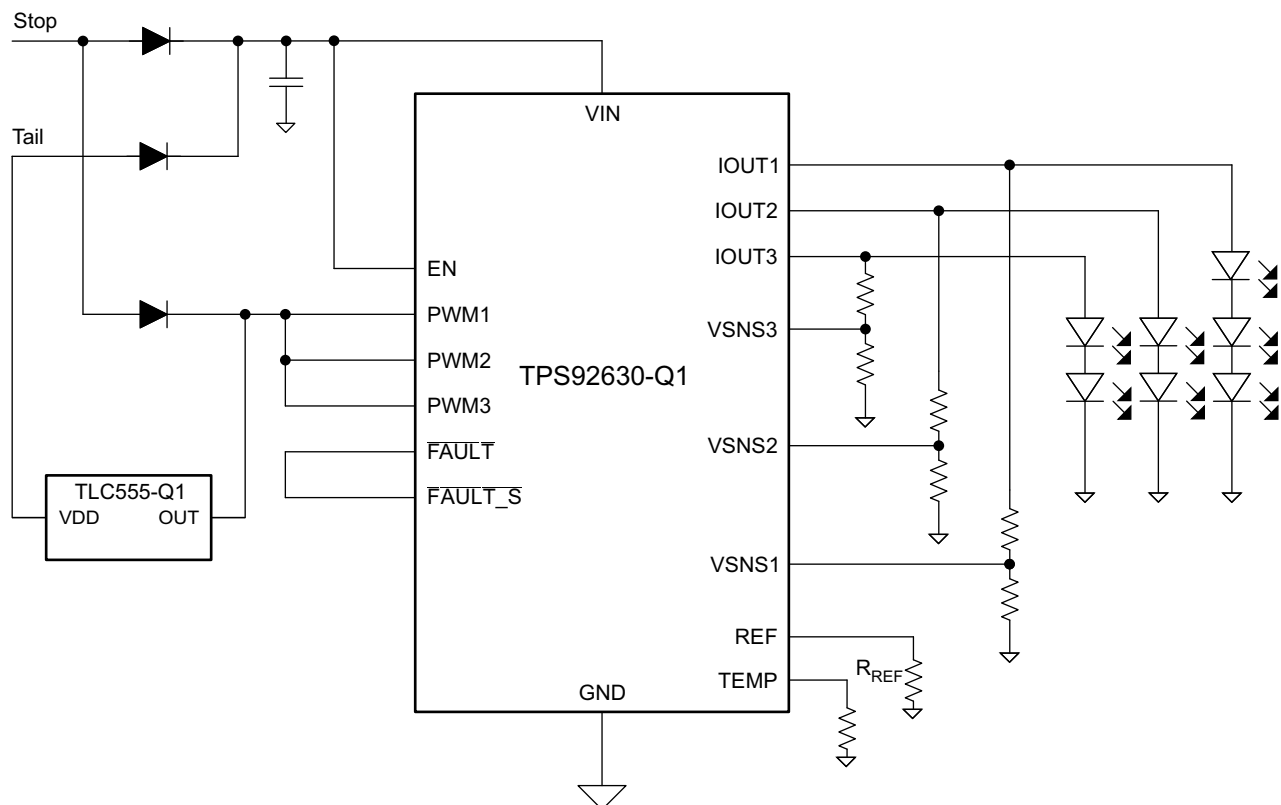

Figure 26. Two-Level Brightness Adjustment Using the TPS92630-Q1 With PWM

#### 10.2.2.1 Design Requirements

For this design example, use the following as the input parameters.



Table 3. Design Parameters

DESIGN PARAMETER	EXAMPLE VALUE
$I_{(tail)}$	75
$I_{(stop)}$	150

10.2.2.2 Detailed Design Procedure

10.2.2.2.1 Step-by-Step Design Procedure

To begin the design process, one must decide on a few parameters. The designer must know the following:

- $I_{(tail)}$  – Taillight current
- $I_{(stop)}$  – Stop-light current

10.2.2.2.1.1  $R_{(REF)}$

$$R_{(REF)} = V_{ref} \times K_{(I)} / I_{(stop)} = 1.222 \times 100 / 0.15 = 814 \Omega$$

10.2.2.2.1.2 Duty Cycle

$$\text{Duty cycle} = I_{(tail)} / I_{(stop)} = 75 / 150 = 50\%$$

10.2.2.3 Parallel TPS92630-Q1 Application Curve

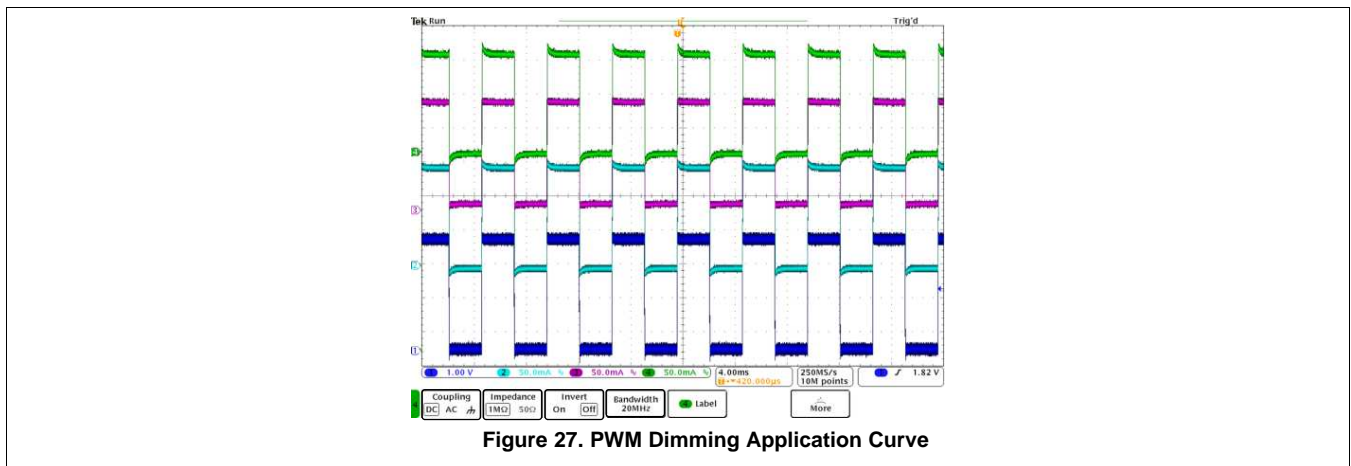
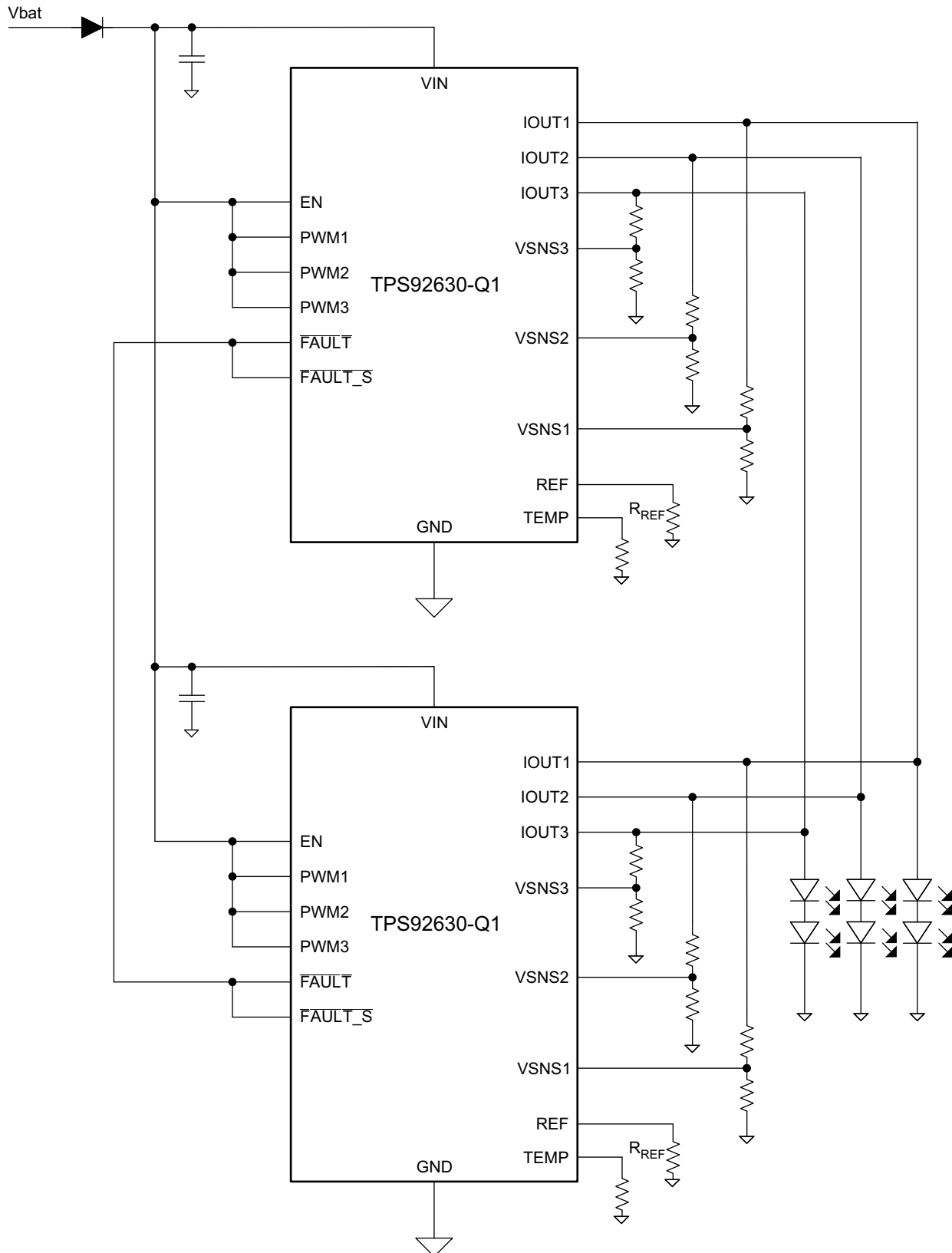

Figure 27. PWM Dimming Application Curve

10.2.3 Parallel Connection

This device can drive up to three strings with one to three LEDs in each string, at a total current up to 150 mA per channel. Outputs can be paralleled to provide higher current drive up to 450 mA. For example, if the load current is up to 2 times the device rating, connect the outputs of two devices in parallel as shown in Figure 28.



**Figure 28. Two TPS92630-Q1 Devices in Parallel for Large Loads**

### 10.2.3.1 Design Requirements

For this design example, use the following as the input parameters.

**Table 4. Design Parameters**

DESIGN PARAMETER	EXAMPLE VALUE
$I_{(LED)}$ per string	200 mA

### 10.2.3.2 Detailed Design Procedure

#### 10.2.3.2.1 Step-by-Step Design Procedure

To begin the design process, one must decide on a few parameters. The designer must know the following:

- $I_{(LED)}$  per string

##### 10.2.3.2.1.1 $R_{(REF)}$

$$R_{(REF)} = V_{ref} \times K_{(I)} / (I_{(LED)} / \text{Channel}) = 1.222 \times 100 / (200 / 2) = 1.222 \text{ k}\Omega$$

### 10.2.4 Alternate Parallel Connection

An alternate method of connecting two devices in parallel drives six LEDs while getting better thermal performance. See [Figure 29](#).

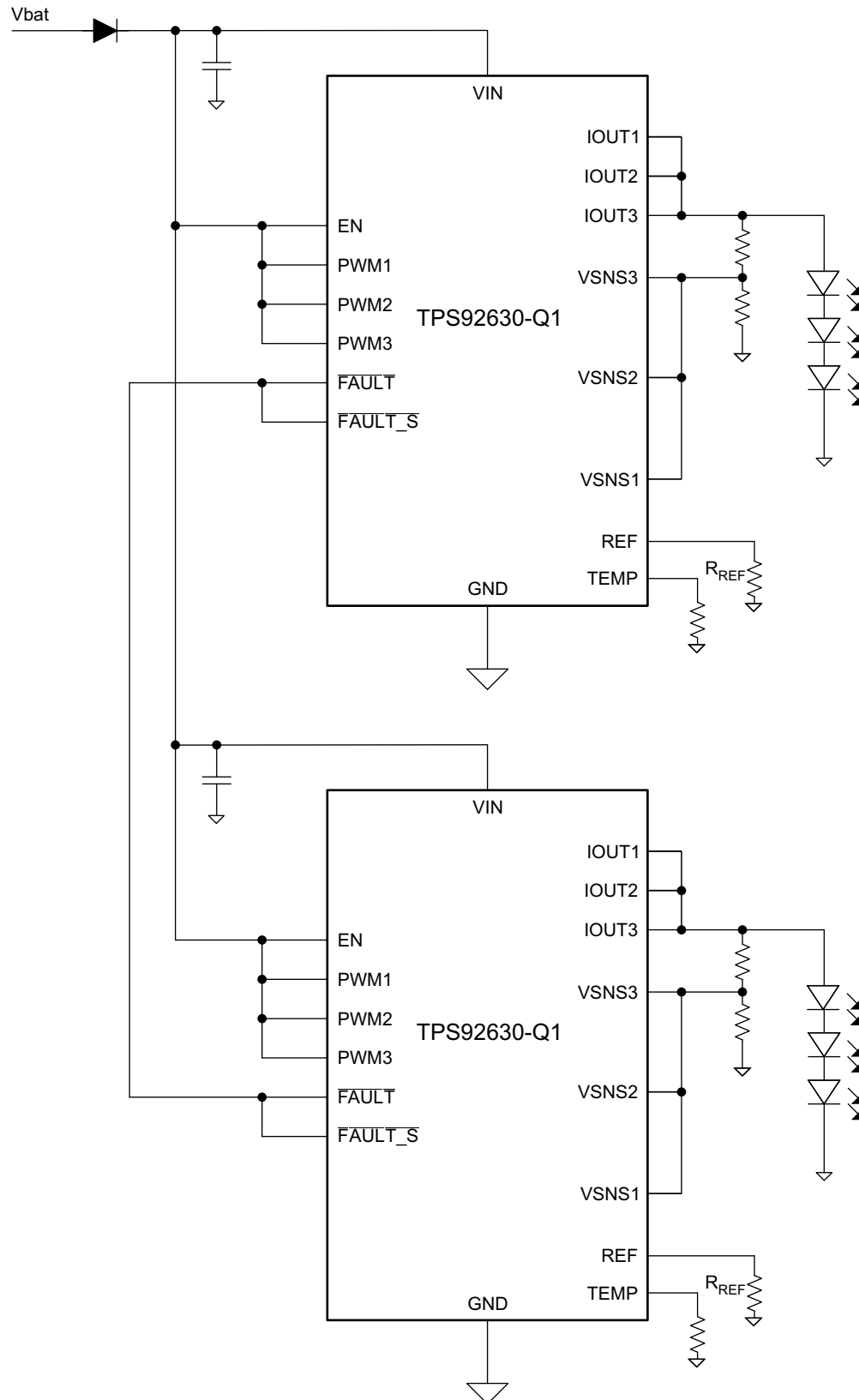

Figure 29. Two TPS92630-Q1 Devices in Parallel for Large Loads

### 10.2.4.1 Design Requirements

For this design example, use the following as the input parameters.

**Table 5. Design Parameters**

DESIGN PARAMETER	EXAMPLE VALUE
$I_{(LED)}$ per string	300 mA

### 10.2.4.2 Detailed Design Procedure

#### 10.2.4.2.1 Step-by-Step Design Procedure

To begin the design process, one must decide on a few parameters. The designer must know the following:

- $I_{(LED)}$  per string

##### 10.2.4.2.1.1 $R_{(REF)}$

$$R_{(REF)} = V_{ref} \times K_{(I)} / (I_{(LED)} / \text{channel}) = 1.222 \times 100 / (300 / 3) = 1.222 \text{ k}\Omega$$

### 10.2.5 High-Side PWM Dimming

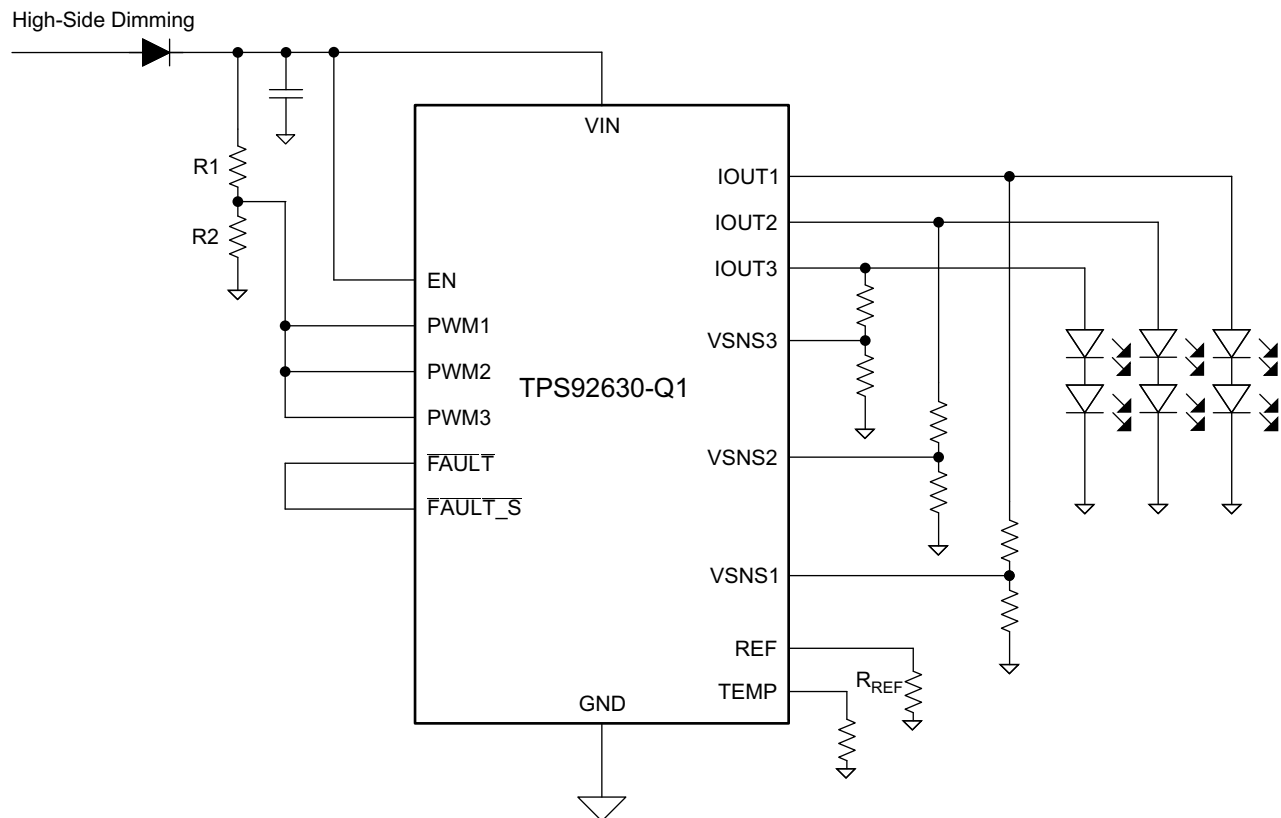

**Figure 30. High-Side PWM Dimming**

### 10.2.5.1 Design Requirements

For this design example, use the following as the input parameters.

**Table 6. Design Parameters**

DESIGN PARAMETER	EXAMPLE VALUE
$V_{(VIN-low)}$	7

### 10.2.5.2 Detailed Design Procedure

If the system has no MCU or PWM, one can use the high-side driver to do the dimming directly. When using the high-side driver to do PWM dimming, a resistor divider must be put in the PWM pin in case of current overshoot on the PWM rising edge. The resistor divider is needed to turn off the channel before the next PWM rising edge.

#### 10.2.5.2.1 Step-by-Step Design Procedure

To begin the design process, one must decide on a parameter. The designer must know the value for  $V_{(VIN-low)}$ .

##### 10.2.5.2.1.1 Ratio of Resistors, R1 / R2

First, measure the voltage on the VIN terminal when the high-side dimming voltage is at a low level. Then calculate the ratio of R1 / R2 using the formula of [Equation 3](#)

[Equation 3](#)

$$\frac{R1}{R2} = \frac{V_{(VIN-low)} + 0.1}{1.178 \times 0.95} \quad (3)$$

Assuming that the measured voltage was 7 V, the R1 / R2 ratio would be 5.25.

##### 10.2.5.2.1.2 R1 and R2 Selection

Select R1 = 105 kΩ and R2 = 20 kΩ.

## 11 Power Supply Recommendations

The TPS9263x-Q1 device is qualified for automotive applications. The normal power supply connection is therefore to an automobile electrical system that provides a voltage within the range specified in the [Recommended Operating Conditions](#).

## 12 Layout

### 12.1 Layout Guidelines

In order to prevent thermal shutdown,  $T_J$  must be less than 150°C. If the input voltage is very high, the power dissipation might be large. Currently there is the TSSOP-EP package which has good thermal impedance, but at the same time, the PCB layout is also very important. Good PCB design can optimize heat transfer, which is absolutely essential for the long-term reliability of the device.

- Maximize the copper coverage on the PCB to increase the thermal conductivity of the board, because the major heat-flow path from the package to the ambient is through the copper on the PCB. Maximum copper is extremely important when there are not any heat sinks attached to the PCB on the other side of the package.
- Add as many thermal vias as possible directly under the package ground pad to optimize the thermal conductivity of the board.
- All thermal vias should be either plated shut or plugged and capped on both sides of the board to prevent solder voids. To ensure reliability and performance, the solder coverage should be at least 85 percent.

### 12.2 Layout Example

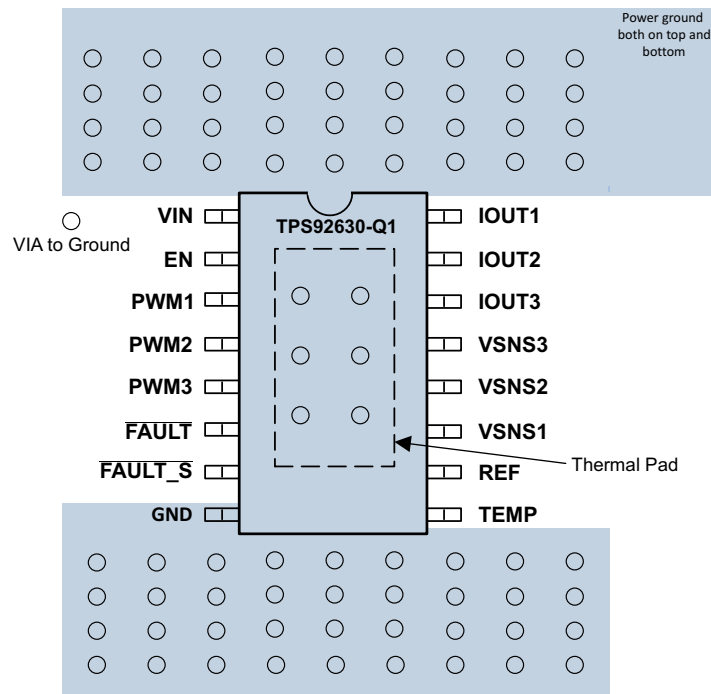

Figure 31. TPS92630-Q1 Board Layout Diagram

## 13 Device and Documentation Support

### 13.1 Related Links

The table below lists quick access links. Categories include technical documents, support and community resources, tools and software, and quick access to sample or buy.

**Table 7. Related Links**

PARTS	PRODUCT FOLDER	SAMPLE & BUY	TECHNICAL DOCUMENTS	TOOLS & SOFTWARE	SUPPORT & COMMUNITY
TPS92630-Q1	<a href="#">Click here</a>	<a href="#">Click here</a>	<a href="#">Click here</a>	<a href="#">Click here</a>	<a href="#">Click here</a>
TPS92631-Q1	<a href="#">Click here</a>	<a href="#">Click here</a>	<a href="#">Click here</a>	<a href="#">Click here</a>	<a href="#">Click here</a>

### 13.2 Trademarks

PowerPAD is a trademark of Texas Instruments.  
 All other trademarks are the property of their respective owners.

### 13.3 Electrostatic Discharge Caution



This integrated circuit can be damaged by ESD. Texas Instruments recommends that all integrated circuits be handled with appropriate precautions. Failure to observe proper handling and installation procedures can cause damage.

ESD damage can range from subtle performance degradation to complete device failure. Precision integrated circuits may be more susceptible to damage because very small parametric changes could cause the device not to meet its published specifications.

### 13.4 Glossary

[SLYZ022](#) — *TI Glossary*.

This glossary lists and explains terms, acronyms and definitions.



## 14 Mechanical, Packaging, and Orderable Information

The following pages include mechanical packaging and orderable information. This information is the most current data available for the designated devices. This data is subject to change without notice and revision of this document. For browser-based versions of this data sheet, refer to the left-hand navigation.

**PACKAGING INFORMATION**

Orderable Device	Status (1)	Package Type	Package Drawing	Pins	Package Qty	Eco Plan (2)	Lead/Ball Finish (6)	MSL Peak Temp (3)	Op Temp (°C)	Device Marking (4/5)	Samples
TPS92630QPWRQ1	PREVIEW	HTSSOP	PWP	16	2000	Green (RoHS & no Sb/Br)	CU NIPDAU	Level-3-260C-168 HR	-40 to 125		

(1) The marketing status values are defined as follows:

**ACTIVE:** Product device recommended for new designs.

**LIFEBUY:** TI has announced that the device will be discontinued, and a lifetime-buy period is in effect.

**NRND:** Not recommended for new designs. Device is in production to support existing customers, but TI does not recommend using this part in a new design.

**PREVIEW:** Device has been announced but is not in production. Samples may or may not be available.

**OBSELETE:** TI has discontinued the production of the device.

(2) Eco Plan - The planned eco-friendly classification: Pb-Free (RoHS), Pb-Free (RoHS Exempt), or Green (RoHS & no Sb/Br) - please check <http://www.ti.com/productcontent> for the latest availability information and additional product content details.

**TBD:** The Pb-Free/Green conversion plan has not been defined.

**Pb-Free (RoHS):** TI's terms "Lead-Free" or "Pb-Free" mean semiconductor products that are compatible with the current RoHS requirements for all 6 substances, including the requirement that lead not exceed 0.1% by weight in homogeneous materials. Where designed to be soldered at high temperatures, TI Pb-Free products are suitable for use in specified lead-free processes.

**Pb-Free (RoHS Exempt):** This component has a RoHS exemption for either 1) lead-based flip-chip solder bumps used between the die and package, or 2) lead-based die adhesive used between the die and leadframe. The component is otherwise considered Pb-Free (RoHS compatible) as defined above.

**Green (RoHS & no Sb/Br):** TI defines "Green" to mean Pb-Free (RoHS compatible), and free of Bromine (Br) and Antimony (Sb) based flame retardants (Br or Sb do not exceed 0.1% by weight in homogeneous material)

(3) MSL, Peak Temp. - The Moisture Sensitivity Level rating according to the JEDEC industry standard classifications, and peak solder temperature.

(4) There may be additional marking, which relates to the logo, the lot trace code information, or the environmental category on the device.

(5) Multiple Device Markings will be inside parentheses. Only one Device Marking contained in parentheses and separated by a "~" will appear on a device. If a line is indented then it is a continuation of the previous line and the two combined represent the entire Device Marking for that device.

(6) Lead/Ball Finish - Orderable Devices may have multiple material finish options. Finish options are separated by a vertical ruled line. Lead/Ball Finish values may wrap to two lines if the finish value exceeds the maximum column width.

**Important Information and Disclaimer:** The information provided on this page represents TI's knowledge and belief as of the date that it is provided. TI bases its knowledge and belief on information provided by third parties, and makes no representation or warranty as to the accuracy of such information. Efforts are underway to better integrate information from third parties. TI has taken and continues to take reasonable steps to provide representative and accurate information but may not have conducted destructive testing or chemical analysis on incoming materials and chemicals. TI and TI suppliers consider certain information to be proprietary, and thus CAS numbers and other limited information may not be available for release.

In no event shall TI's liability arising out of such information exceed the total purchase price of the TI part(s) at issue in this document sold by TI to Customer on an annual basis.



PWP (R-PDSO-G16)

PowerPAD™ PLASTIC SMALL OUTLINE

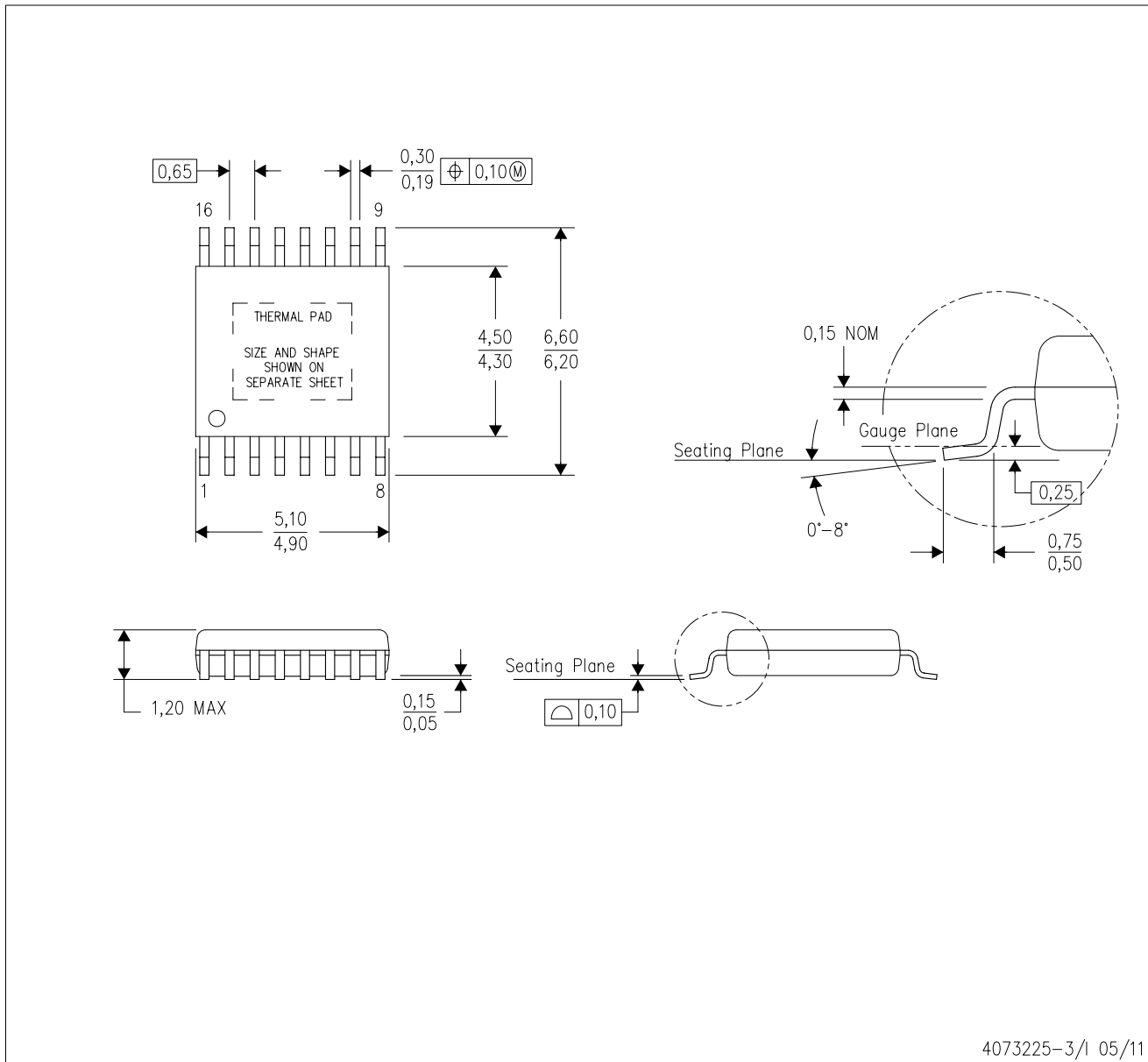

4073225-3/1 05/11

- NOTES:
- A. All linear dimensions are in millimeters.
  - B. This drawing is subject to change without notice.
  - C. Body dimensions do not include mold flash or protrusions. Mold flash and protrusion shall not exceed 0.15 per side.
  - D. This package is designed to be soldered to a thermal pad on the board. Refer to Technical Brief, PowerPad Thermally Enhanced Package, Texas Instruments Literature No. SLMA002 for information regarding recommended board layout. This document is available at [www.ti.com](http://www.ti.com) <<http://www.ti.com>>.
  - E. See the additional figure in the Product Data Sheet for details regarding the exposed thermal pad features and dimensions.
  - E. Falls within JEDEC MO-153

PowerPAD is a trademark of Texas Instruments.

## IMPORTANT NOTICE

Texas Instruments Incorporated and its subsidiaries (TI) reserve the right to make corrections, enhancements, improvements and other changes to its semiconductor products and services per JESD46, latest issue, and to discontinue any product or service per JESD48, latest issue. Buyers should obtain the latest relevant information before placing orders and should verify that such information is current and complete. All semiconductor products (also referred to herein as "components") are sold subject to TI's terms and conditions of sale supplied at the time of order acknowledgment.

TI warrants performance of its components to the specifications applicable at the time of sale, in accordance with the warranty in TI's terms and conditions of sale of semiconductor products. Testing and other quality control techniques are used to the extent TI deems necessary to support this warranty. Except where mandated by applicable law, testing of all parameters of each component is not necessarily performed.

TI assumes no liability for applications assistance or the design of Buyers' products. Buyers are responsible for their products and applications using TI components. To minimize the risks associated with Buyers' products and applications, Buyers should provide adequate design and operating safeguards.

TI does not warrant or represent that any license, either express or implied, is granted under any patent right, copyright, mask work right, or other intellectual property right relating to any combination, machine, or process in which TI components or services are used. Information published by TI regarding third-party products or services does not constitute a license to use such products or services or a warranty or endorsement thereof. Use of such information may require a license from a third party under the patents or other intellectual property of the third party, or a license from TI under the patents or other intellectual property of TI.

Reproduction of significant portions of TI information in TI data books or data sheets is permissible only if reproduction is without alteration and is accompanied by all associated warranties, conditions, limitations, and notices. TI is not responsible or liable for such altered documentation. Information of third parties may be subject to additional restrictions.

Resale of TI components or services with statements different from or beyond the parameters stated by TI for that component or service voids all express and any implied warranties for the associated TI component or service and is an unfair and deceptive business practice. TI is not responsible or liable for any such statements.

Buyer acknowledges and agrees that it is solely responsible for compliance with all legal, regulatory and safety-related requirements concerning its products, and any use of TI components in its applications, notwithstanding any applications-related information or support that may be provided by TI. Buyer represents and agrees that it has all the necessary expertise to create and implement safeguards which anticipate dangerous consequences of failures, monitor failures and their consequences, lessen the likelihood of failures that might cause harm and take appropriate remedial actions. Buyer will fully indemnify TI and its representatives against any damages arising out of the use of any TI components in safety-critical applications.

In some cases, TI components may be promoted specifically to facilitate safety-related applications. With such components, TI's goal is to help enable customers to design and create their own end-product solutions that meet applicable functional safety standards and requirements. Nonetheless, such components are subject to these terms.

No TI components are authorized for use in FDA Class III (or similar life-critical medical equipment) unless authorized officers of the parties have executed a special agreement specifically governing such use.

Only those TI components which TI has specifically designated as military grade or "enhanced plastic" are designed and intended for use in military/aerospace applications or environments. Buyer acknowledges and agrees that any military or aerospace use of TI components which have **not** been so designated is solely at the Buyer's risk, and that Buyer is solely responsible for compliance with all legal and regulatory requirements in connection with such use.

TI has specifically designated certain components as meeting ISO/TS16949 requirements, mainly for automotive use. In any case of use of non-designated products, TI will not be responsible for any failure to meet ISO/TS16949.

### Products

Audio	<a href="http://www.ti.com/audio">www.ti.com/audio</a>
Amplifiers	<a href="http://amplifier.ti.com">amplifier.ti.com</a>
Data Converters	<a href="http://dataconverter.ti.com">dataconverter.ti.com</a>
DLP® Products	<a href="http://www.dlp.com">www.dlp.com</a>
DSP	<a href="http://dsp.ti.com">dsp.ti.com</a>
Clocks and Timers	<a href="http://www.ti.com/clocks">www.ti.com/clocks</a>
Interface	<a href="http://interface.ti.com">interface.ti.com</a>
Logic	<a href="http://logic.ti.com">logic.ti.com</a>
Power Mgmt	<a href="http://power.ti.com">power.ti.com</a>
Microcontrollers	<a href="http://microcontroller.ti.com">microcontroller.ti.com</a>
RFID	<a href="http://www.ti-rfid.com">www.ti-rfid.com</a>
OMAP Applications Processors	<a href="http://www.ti.com/omap">www.ti.com/omap</a>
Wireless Connectivity	<a href="http://www.ti.com/wirelessconnectivity">www.ti.com/wirelessconnectivity</a>

### Applications

Automotive and Transportation	<a href="http://www.ti.com/automotive">www.ti.com/automotive</a>
Communications and Telecom	<a href="http://www.ti.com/communications">www.ti.com/communications</a>
Computers and Peripherals	<a href="http://www.ti.com/computers">www.ti.com/computers</a>
Consumer Electronics	<a href="http://www.ti.com/consumer-apps">www.ti.com/consumer-apps</a>
Energy and Lighting	<a href="http://www.ti.com/energy">www.ti.com/energy</a>
Industrial	<a href="http://www.ti.com/industrial">www.ti.com/industrial</a>
Medical	<a href="http://www.ti.com/medical">www.ti.com/medical</a>
Security	<a href="http://www.ti.com/security">www.ti.com/security</a>
Space, Avionics and Defense	<a href="http://www.ti.com/space-avionics-defense">www.ti.com/space-avionics-defense</a>
Video and Imaging	<a href="http://www.ti.com/video">www.ti.com/video</a>

### TI E2E Community

[e2e.ti.com](http://e2e.ti.com)